

Energy Measurement

2012 Product Portfolio



Energy Measurement Redefined

As the high-precision leader in Analog Front End (AFE) ICs for energy measurement since 1999, Cirrus Logic chips have helped to drive revolutionary, cutting-edge products that are at the heart of global smart grids and smart power applications.

Cirrus Logic's broad family of AFE products have each been developed around three common principles:

- Highest precision measurement in the industry
- Ease of use and flexibility
- Lowest cost

New generations of energy measurement applications are driving innovation beyond the utility meter. Smart plugs, smart appliances and power supplies for intense-use applications are enabling businesses, enterprises and even consumers to more accurately account for their energy usage. Armed with relevant data, consumers can now use that information to make smarter decisions to manage their energy consumption.

Smart energy measurement is all about using the electric grid more efficiently!

Cirrus Logic focuses solely on developing the best AFE products in the semiconductor industry, freeing designers to use the MCU of their choice in their design. This approach enables customers to optimize performance and price on every platform and provides flexibility across platforms to meet changing market requirements.

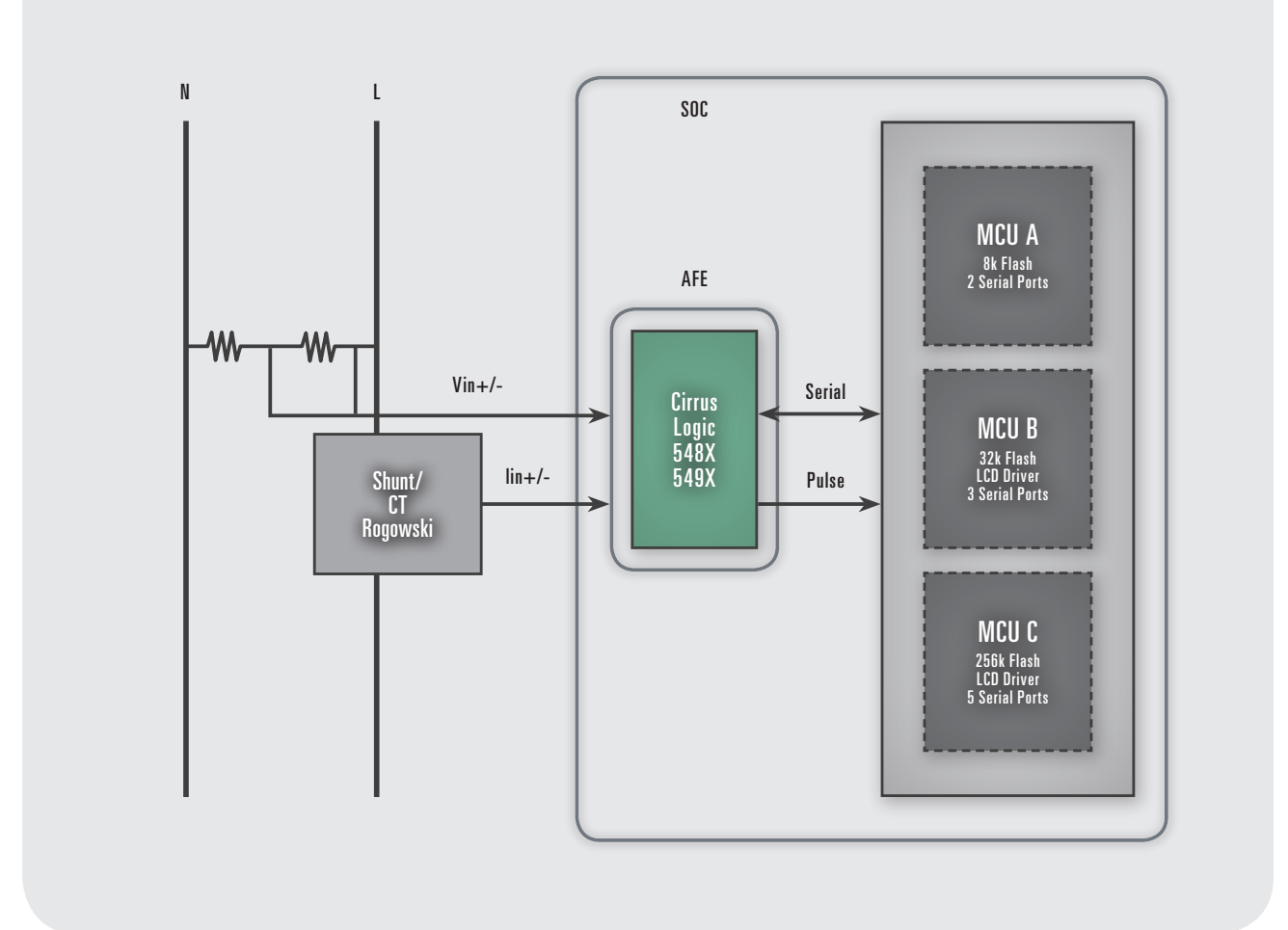

The AFE+MCU Advantage

Designers have a fundamental choice for their application: SOCs that offer a limited “one size fits all” approach, or a dedicated MCU of their choice combined with a Cirrus Logic AFE solutions with several benefits:

- Highest measurement accuracy in the industry, with low cost
- Up to 10X faster calibration
- Flexibility to tailor application to performance needs and market demands

With this approach, each designer has the flexibility to choose an MCU with the combination of memory, LCD drive and I/O that is ideal for their specific application.

SOCs on the market today generally combine some AFE functionality with predefined microcontroller functionality in a single package. As the result, designers who use

SOCs often pay for unnecessary features (eg. memory) and lesser performance — at a higher cost.

Cirrus Logic AFEs offer the lowest noise level, highest signal-to-noise ratios and best accuracy available. Through pairing of the Cirrus Logic AFE with the microcontroller of their choice, OEMs have the ability to cost optimize their design while also obtaining a device with superior measurement accuracy (the Cirrus Logic AFE) and the processing features and performance that they select from among a host of MCU vendors.

Using a Cirrus Logic AFE + MCU will help drive down the bill of materials for any design task while giving customers the flexibility to meet rapidly changing market requirements.

A Smarter Approach

Cirrus Logic Analog Front Ends (AFEs) are the first choice for today's smart metering solutions.

Unlike expensive SOCs, our AFEs allow the flexibility of designing with a wide range of third-party microcontrollers to optimize for your specific application requirements.

Don't spend time worrying about how to make an SOC fit into your design. Make the smarter choice for your metering needs with Cirrus Logic's flexible, cost-effective AFE solutions.



Digital Utility Meters

Cirrus Logic AFEs for digital utility meters have shaped the global roll out of new generations of digital electric utility meters for more than a decade. Working closely with leading global smart meter OEMs, Cirrus has helped to define and build ICs that have enabled the cost-effective deployment of high-accuracy smart meters that have directly contributed to the development of smart grids throughout the world.

Cirrus Logic's advantages in this market:

HIGHEST ACCURACY: We understand accuracy requirements driven by utilities and local regulators, and can help you meet any global standard. Our accuracy performance is very flat over a long range, and ultra-low noise level and high SNR make us the market leader in accuracy.

LOW COST: We take deliberate efforts to keep our costs extremely low. Optimizing die sizes, building our devices as hard coded ROMs and avoiding expensive flash memory and designing AFEs using cost optimized process technology allows us to pass on the cost benefit to our customers.

FAST CALIBRATION: Customers who want fast calibration need not look any further than Cirrus AFEs. Due to our superior analog performance, offset correction is very fast. With a calibration time of 2-3 seconds, we are up to 10 times quicker than many competing SOC solutions, which significantly speeds production.

FLEXIBILITY: Cirrus' AFE approach allows the customers to lock in the metrology portion of their designs across the globe and free up their designers to focus on selecting the appropriate MCU to satisfy the local requirements for communications, LCD drive, IO etc.

EASE OF USE: Pre-programmed power calculation engine eliminates any need for manual programming and also mitigates security concerns.

CS5490: Single-phase, 2-channel Utility Meter
(with shunt resistor)

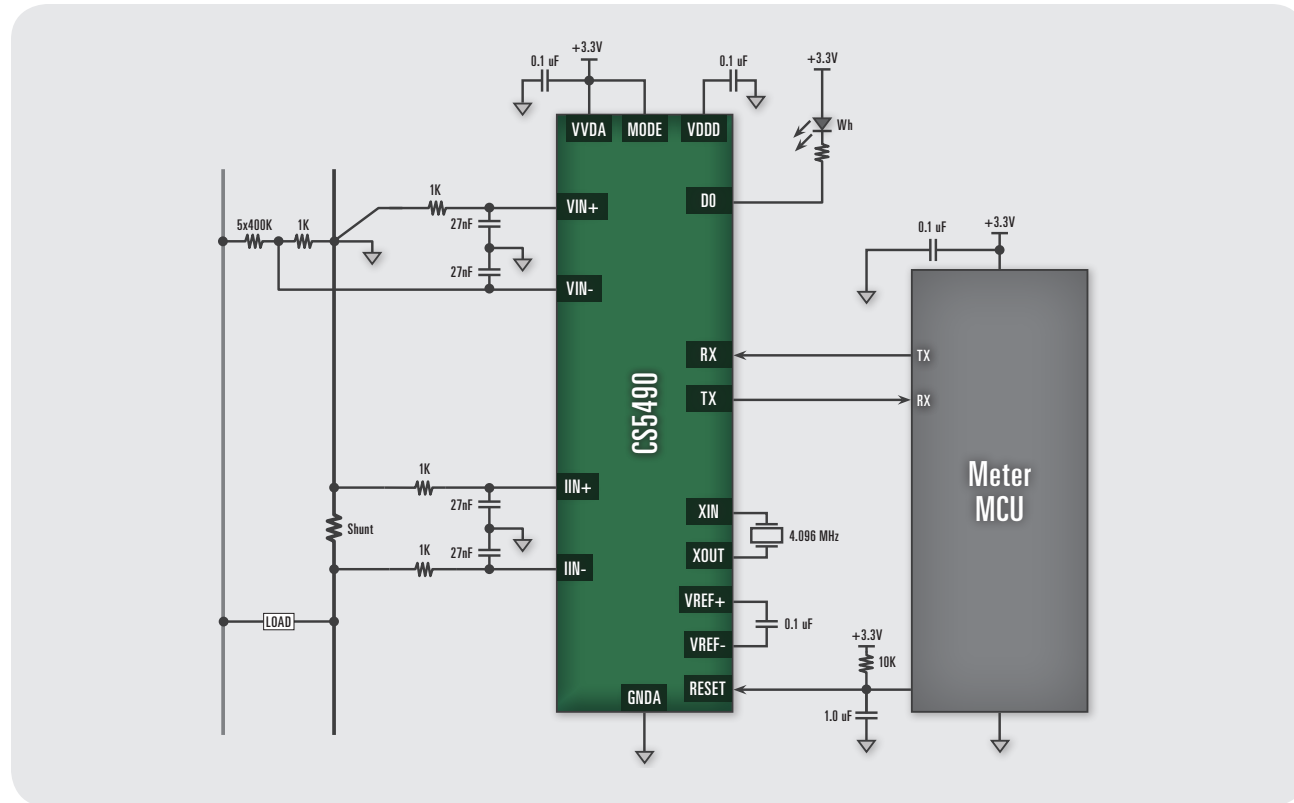

CS5484: Single-phase 4-channel Utility Meter
(2 current transformers or 2 Rogowski coils)

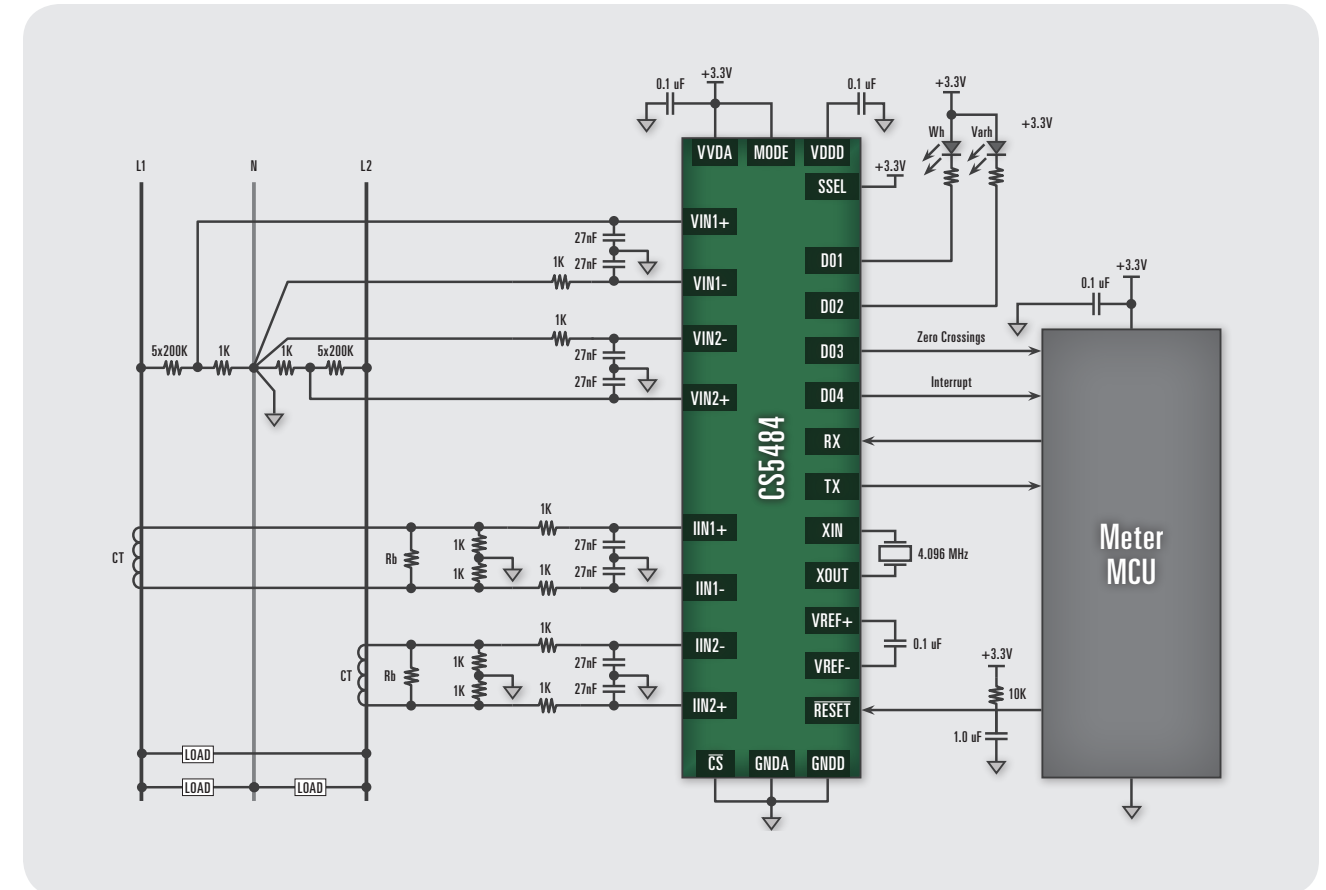

CS5480: Single-phase, 3-channel Utility Meter
(current transformer and shunt resistor)

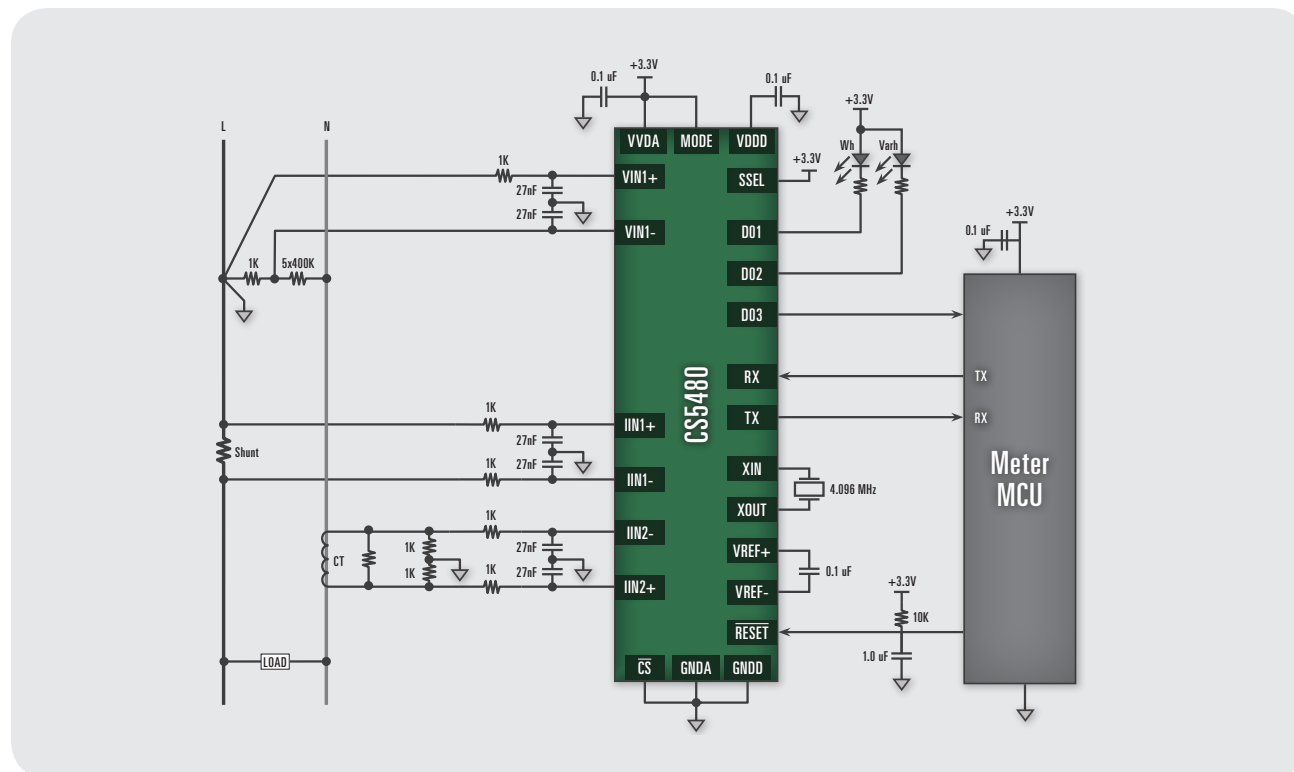

Product	Description	Cirrus Logic Solution	Benefits
CS5490 CS5484 CS5480	2, 3 or 4 channel analog front end	High-performance 24-bit analog to digital converters combined with a proven power calculation engine.	Extremely high energy measurement accuracy across a broad dynamic range. Proven power calculation engine is built-in; user programming is not required. Fast calibration minimizes time required at the end of customer's production line. Analog front end approach enables customers to maintain flexibility to choose the right application processor for every platform, and adapt quickly to changing requirements. Customers will never pay for more memory, IO or performance than required.

3-phase Utility Meters

In an effort to provide the most accurate and cost effective three-phase solution possible, Cirrus Logic utilizes multiple ICs to provide the required number of high-performance A/D converters. Compared to many single-chip, 3-phase products with 6-8 channels built in, our multichip solutions can cost more than 50 percent less!

The following application diagrams show two alternate solutions for 3-phase utility meters. The first requires three devices and is applied for non-isolated current sensors – typically a shunt resistor. The second requires just two devices and applies to meter configurations with isolated sensors, either current transformers or Rogowski coils.

3-phase Utility Meter with Non-isolated Sensor

Configuration

In the 3-phase configuration Phases A, B, and C are each connected to a separate CS5480 device to provide required isolation. For current measurement, a shunt resistor on each phase is connected to a differential current input on the CS5480. For voltage measurement, a resistor divider network between each phase and neutral is connected to the voltage channel.

Serial communication between each CS5480 and the utility meter MCU is via UART to minimize isolation costs. The applications processor must provide three digital outputs for chip select (CS) one for each CS5480.

Operation

Each CS5480 contains independent 24-bit analog to digital converters (ADCs). The sample rate of each converter is 4k/sps. The meter MCU can read raw sample data from each converter at this data rate and perform power calculations outside of the CS5480.

Another option is to utilize the proven onboard power calculation engine to perform power calculations on-chip. In this configuration, the calculation engine reads the raw data from the ADC channels, performs power calculations, and stores the results in registers for the application processor to read via the serial port. On-chip calculations include instantaneous voltage, current and power, V_{rms} , I_{rms} , active power, reactive power, apparent power, and power factor. Summation of these values across phases is done in the meter MCU. In addition, the CS5480 has included functionality for phase sequence detection and phase angle calculations often required in 3-phase applications.

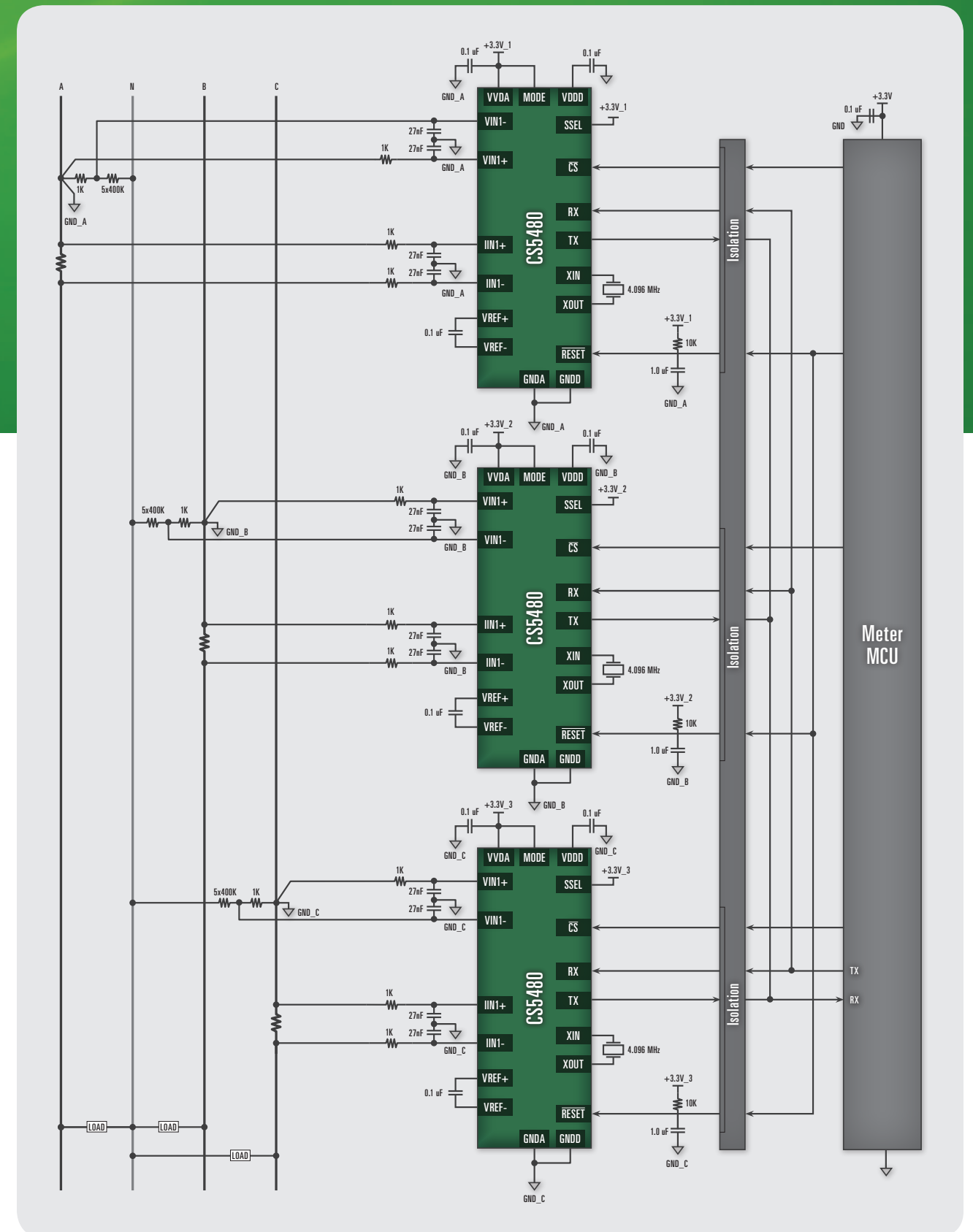

3-phase Utility Meter with Isolated Sensor

Configuration

In the 3-phase wye configuration, Phases A and B are connected to the first CS5484 (top in the diagram) and Phase C is connected to the second CS5484 (bottom in the diagram). For current measurement, a current transformer on each phase is connected to a differential current input on the CS5484. For voltage measurement, a resistor divider network between each phase and neutral is connected to the voltage channel. In a standard configuration of three current and three voltage measurements, the second CS5484 is deployed with an unused current channel (IIN2) and voltage channel (VIN2). These additional channels allow for the option of a Neutral Current measurement for tamper detection, and an additional voltage channel for alternate functionality.

Clock Synchronization

The first CS5484 is connected to an external crystal to provide its clock source. The first CS5484 has a CPUCLK output that provides a synchronized clock source to second CS5484. This arrangement enables synchronous sampling of all voltage and current channels on both devices.

Communication

Serial communication between each CS5484 is via SPI. The CS5484 SPI port operates at up to 2Mbps. A single SPI port is required on the applications processor. In addition, the applications processor must provide two digital outputs for chip select (CS) one for each CS5484.

Operation

Each CS5484 contains four independent 24-bit analog to digital converters (ADCs). With a sample rate for each converter of 4ksps, the applications processor can read raw sample data from each converter at this data rate and perform power calculations outside of the CS5484.

Another option is to utilize the proven onboard power calculation engine to perform power calculations on-chip. In this configuration, the calculation engine reads the raw data from the ADC channels, performs power calculations, and stores the results in registers for the meter MCU to read via the serial port. On-chip calculations include instantaneous voltage, current and power, V_{rms} , I_{rms} , active power, reactive power, apparent power, and power factor. Summation of these values across phases is done in the utility meter MCU. In addition, the CS5484 has included functionality for phase sequence detection and phase angle calculations often required in 3-phase applications.

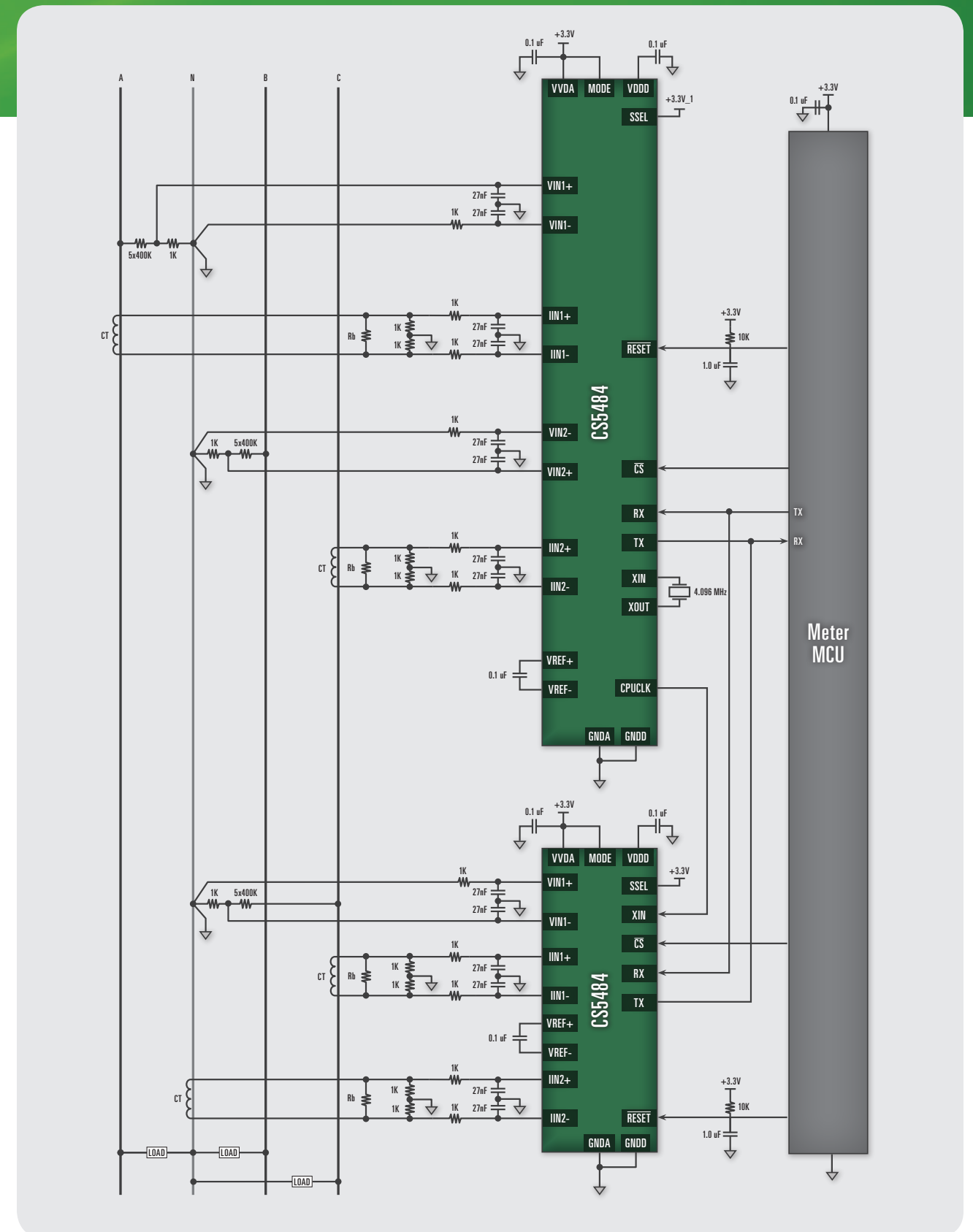



Smart Power

Beyond the utility meter, emerging applications in power monitoring are changing how consumers and businesses think about — and manage — electricity consumption.

Smart appliances (eg. washers/dryers and refrigerators) smart powerstrips/smart plugs and power supplies used in commercial applications like servers can now more than ever cost effectively provide highly accurate information to the user.

In any application where high precision, low cost and ease of use matter to the system designer, Cirrus Logic offers a tailor-made IC — providing just the right level of features and performance.

Smart Appliances

To effectively monitor energy usage within the home, consumers need to understand how their appliances — washing machines, dryers, refrigerators, etc., — consume electricity. For this reason, a new breed of wireless-enabled “smart appliances” have emerged as one of the fastest-growing segments of the energy measurement market.

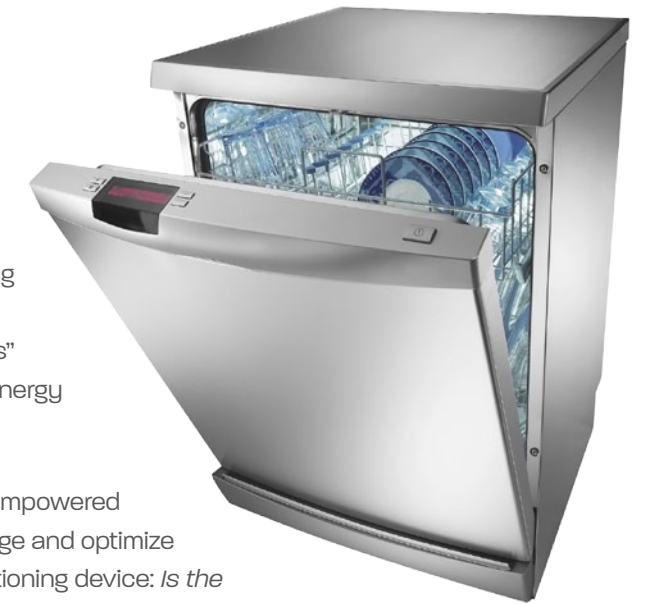

If consumers can, in effect, itemize the consumption, they are empowered with the knowledge to make informed decisions to better manage and optimize overall consumption habits or even perhaps remedy a malfunctioning device: *Is the refrigerator consuming unusually large amounts of electricity? Perhaps the motor is breaking down and needs replacing? If my utility has reduced per-kilowatt-hour pricing at night, perhaps it's less expensive to operate the dryer during that time?*

Smart appliances are able to monitor and report energy consumption, perform advanced diagnostics based on energy use, automatically respond to utility signals for time-of-use rate changes and service malfunctioning devices. These functions provide cost savings to utilities as well as consumers.

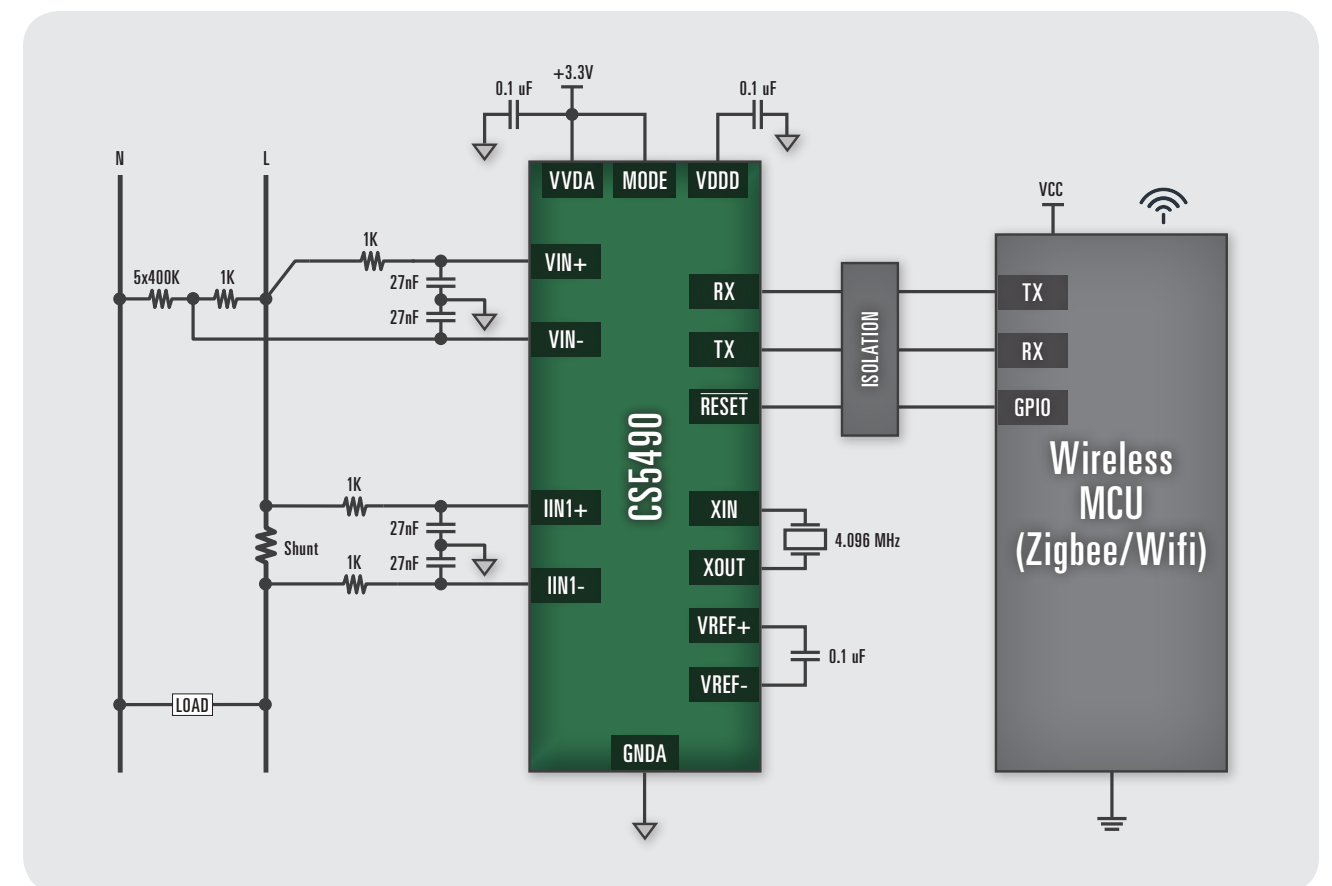



Smart Power Supply

Smart power supply monitoring systems are designed for measuring and relaying energy usage information in high-performance systems such as servers, telecommunications racks, storage racks and PCs. Continuously increasing demand for computer resources such as cloud computing has resulted in exponential growth in the number of data center servers.

Cirrus Logic understands the challenge this presents to IT managers and equipment manufacturers, and through its portfolio of energy measurement ICs, it partners with them to create green data centers through energy efficient solutions such as power-managed servers.

Cirrus Logic works closely with power supply OEMs to make their initial implementation of an energy measurement function in a power supply easy and affordable. To meet OEMs' growing demand for cost-effective implementation, Cirrus' new CS548X/9X family features built-in calculations and very fast calibration, which speeds production cycles and enables customers to use low-cost manufacturing locations.

Cirrus' components enable extremely accurate measurement of energy consumption, allowing data centers to optimize server utilization for efficiency and better return on investment.

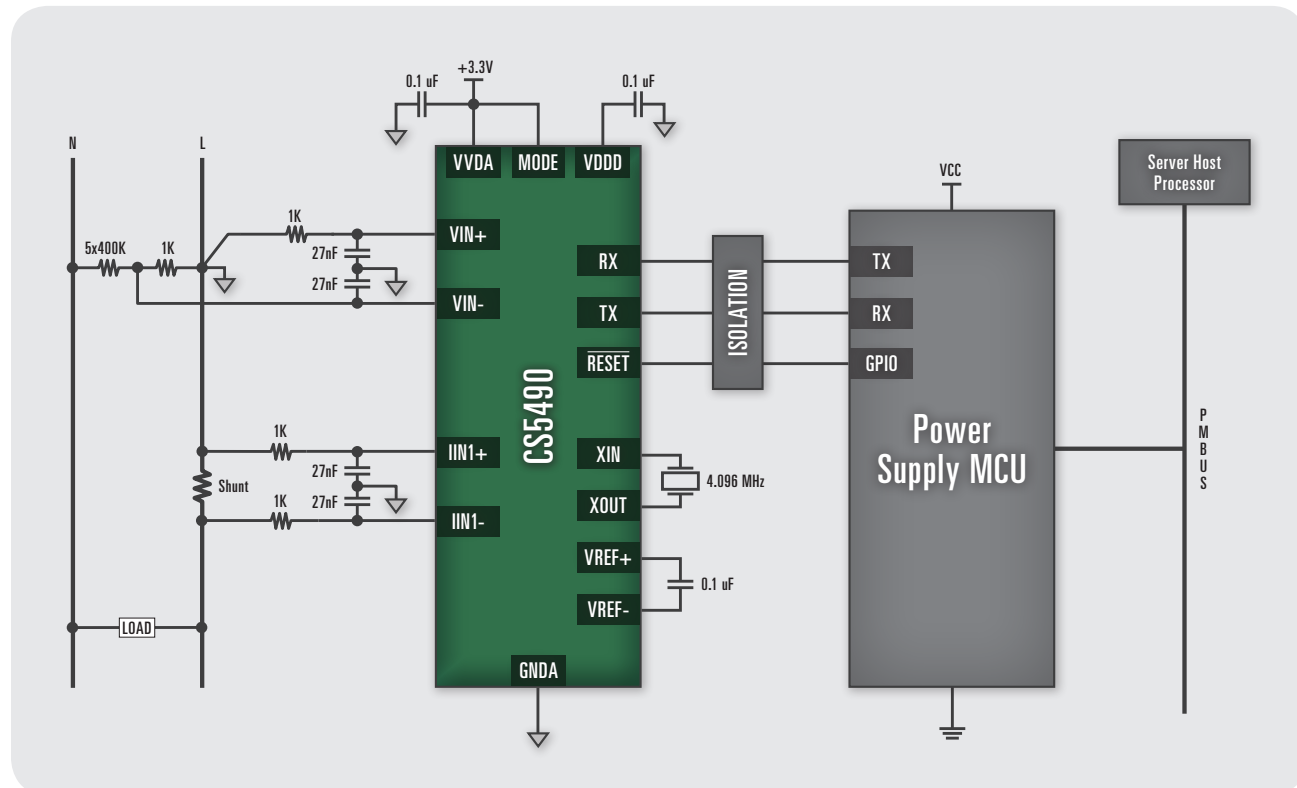

Smart Plug / Smart Strips

Smart plugs and smart powerstrips were, until recent years, unknown consumer devices. These products are a rapidly growing segment of the energy measurement market that is being driven by consumers seeking real-time information about the electricity usage of household products: computers, displays, cable boxes, home theater systems, lamps, etc.

While features vary by manufacturer, smart plugs are outlets that plug into regular household outlets and monitor energy consumption. Via optimized remote on-off control, they enable a reduction in overall energy consumption. Some smart plugs/ smart strips use wireless communication, such as Zigbee or Wi-Fi, to connect to a USB hub that plugs into a home or office computer and compile information from measuring the various devices within the home. In addition, this hub can provide automation to reduce consumption by automatically turning off unused loads.

Low-cost AFE solutions from Cirrus Logic are critical components to meet the cost-sensitive and rapidly-changing requirements of the consumer market.

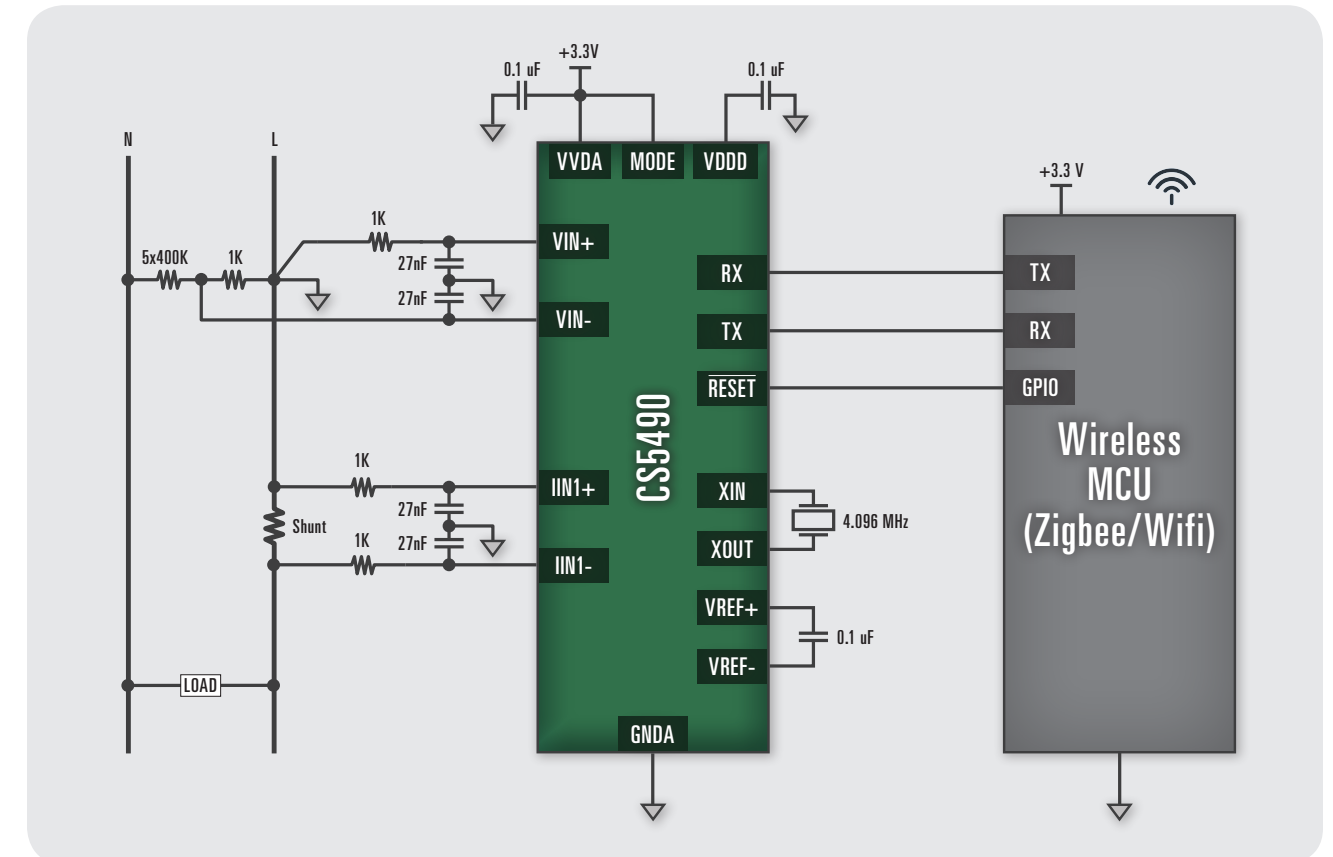

CS5484/80/90 Energy Measurement ICs



Cirrus Logic's EXL Core® is a unique digital approach to developing green energy products. It represents more than 100 patents in signal processing innovation via complex algorithms along with analog peripherals.

CS5484

The CS5484 is a high performance analog front end solution for energy measurement with **four 24-bit analog to digital converters**. It provides high-accuracy energy measurement at a very low price, and on-chip energy calculations and fast on-chip calibration speeds product development cycles. Flexibility in current sensors, serial communications and digital outputs ensures that the CS5484 is a fit for any application requiring high-accuracy energy measurement at a very low price.

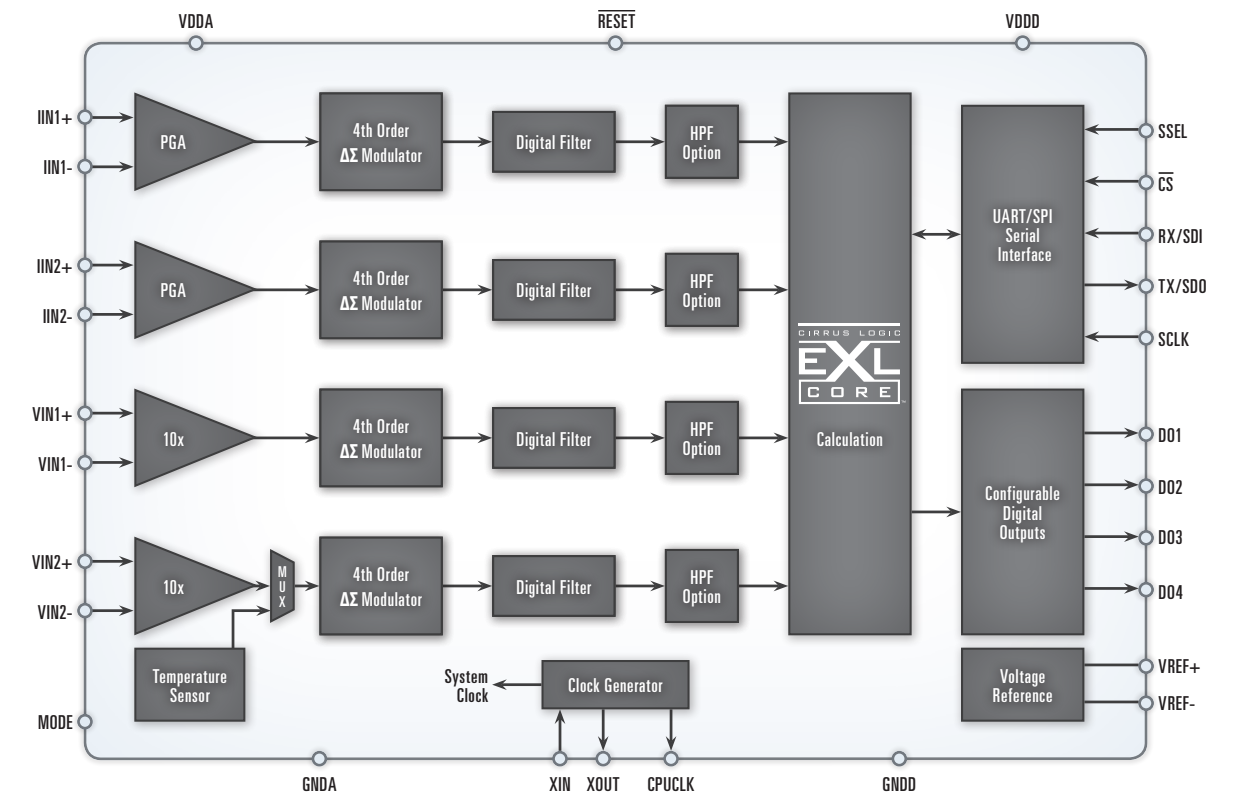

Features:

- Superior analog performance with ultra-low noise level and high SNR
 - Energy measurement accuracy of 0.1% over 4000:1 dynamic range
 - Current RMS measurement accuracy of 0.1% over 1000:1 dynamic range
 - 4 independent 24 bit, 4th order Delta-Sigma modulators for voltage and current measurements
 - 4 configurable digital outputs for energy pulses, zero crossing or energy direction
 - Supports shunt resistor, CT and Rogowski coil current sensors
 - Overcurrent, voltage sag and voltage swell detection
 - UART / SPI serial interface
 - Internal register protection via checksum and write-protection
 - On-chip voltage reference (25 ppm/°C typ.)
 - Single 3.3V power supply
 - Low power consumption: < 13mW
 - 5mm x 5mm 28-pin QFN package
- On-chip measurements / calculations:
- Active, reactive and apparent power
 - RMS voltage and current
 - Power factor and line frequency
 - Instantaneous voltage, current and power

CS5480

The CS5480 is a high performance analog front end solution for energy measurement with **three 24-bit analog to digital converters**. It provides high-accuracy energy measurement at a very low price, and on-chip energy calculations and fast on-chip calibration speeds product development cycles. Flexibility in current sensors, serial communications and digital outputs ensures that the CS5480 is a fit for any application requiring high-accuracy energy measurement at a very low price.

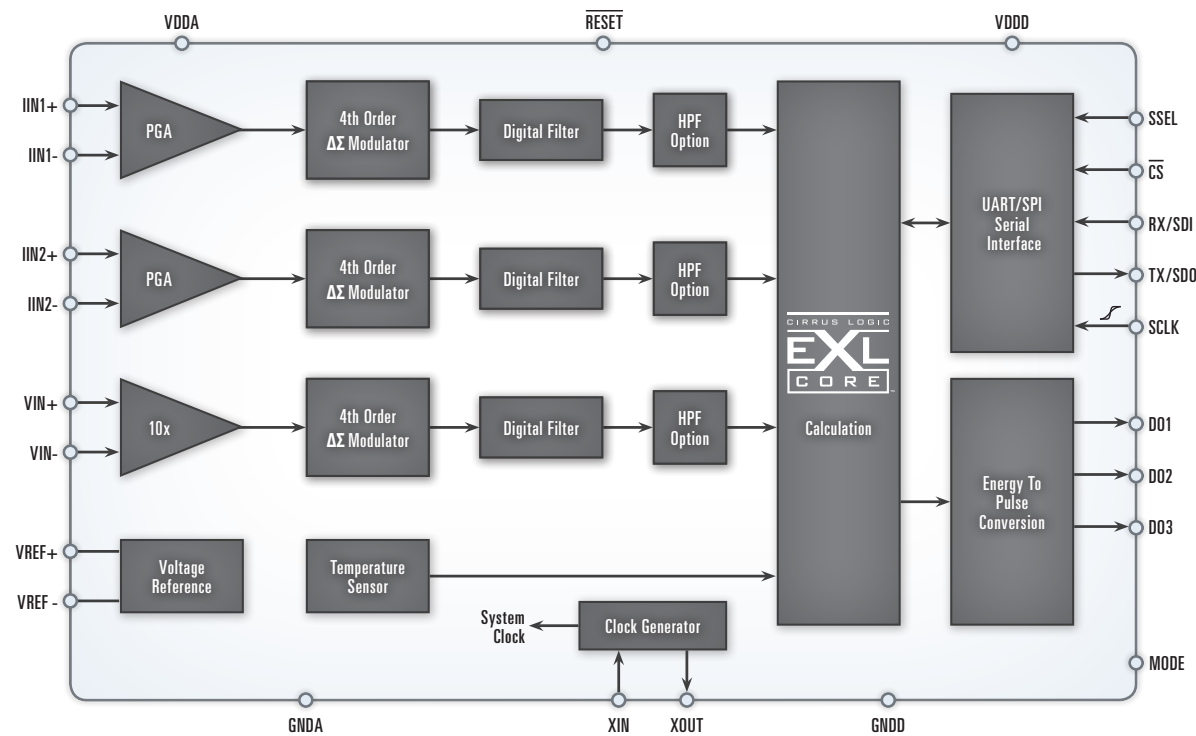

Features:

- Superior analog performance with ultra-low noise level and high SNR
 - Energy measurement accuracy of 0.1% over 4000:1 dynamic range
 - Current RMS measurement accuracy of 0.1% over 1000:1 dynamic range
 - 3 independent 24 bit, 4th order Delta-Sigma modulators for voltage and current measurements
 - 3 configurable digital outputs for energy pulses, zero crossing or energy direction
 - Supports shunt resistor, CT and Rogowski coil current sensors
 - Overcurrent, voltage sag and voltage swell detection
 - UART / SPI serial interface
 - Internal register protection via checksum and write-protection
 - On-chip voltage reference (25 ppm/°C typ.)
 - Single 3.3V power supply
 - Low power consumption: < 13mW
 - 4mm x 4mm 24-pin QFN package
- On-chip measurements / calculations:
- Active, reactive and apparent power
 - RMS voltage and current
 - Power factor and line frequency
 - Instantaneous voltage, current and power

CS5490

The CS5490 is a high performance analog front end solution for energy measurement with **two 24-bit analog to digital converters**. It provides high-accuracy energy measurement at a very low price, and on-chip energy calculations and fast on-chip calibration speeds product development cycles. Flexibility in current sensors and digital outputs ensures that the CS5490 is a fit for any application requiring high-accuracy energy measurement at a very low price.

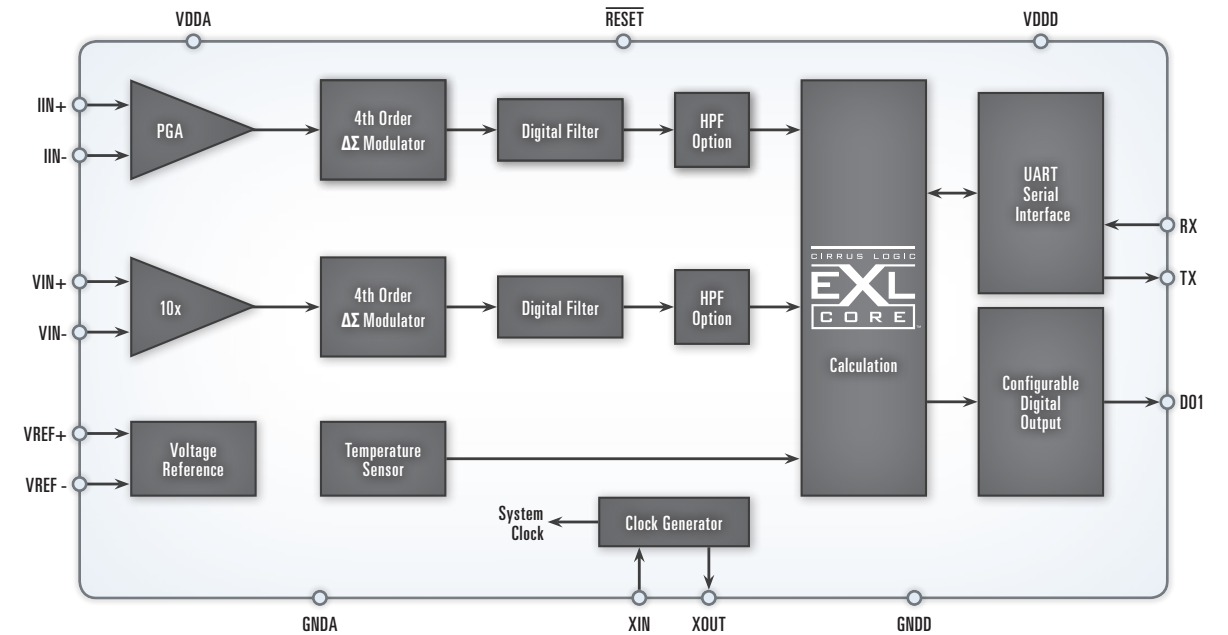

Features:

- Superior analog performance with ultra-low noise level and high SNR
 - Energy measurement accuracy of 0.1% over 1000:1 dynamic range
 - 2 independent 24 bit, 4th order Delta-Sigma modulators for voltage and current measurements
 - Configurable digital output for energy pulses, zero crossing or energy direction
 - Supports shunt resistor, CT and Rogowski coil current sensors
 - Overcurrent, voltage sag and voltage swell detection
 - UART serial interface
 - Internal register protection via checksum and write-protection
 - On-chip voltage reference (25 ppm/°C typ.)
 - Single 3.3V power supply
 - Low power consumption: < 13mW
 - 16-pin SOIC package
- On-chip measurements / calculations:
- Active, reactive and apparent power
 - RMS voltage and current
 - Power factor and line frequency
 - Instantaneous voltage, current and power

Performance Statistics

Product Selector Table

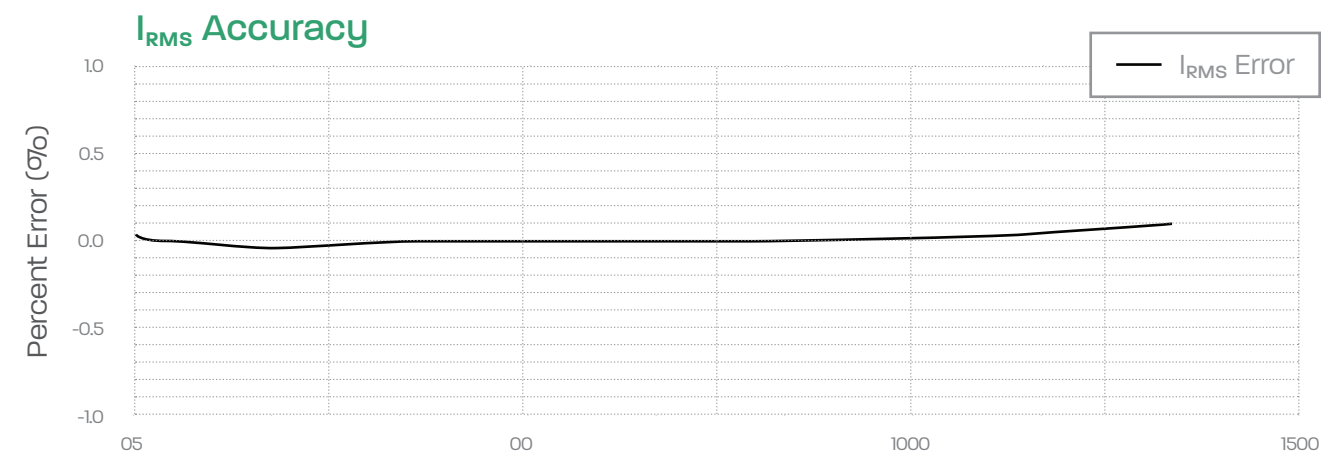
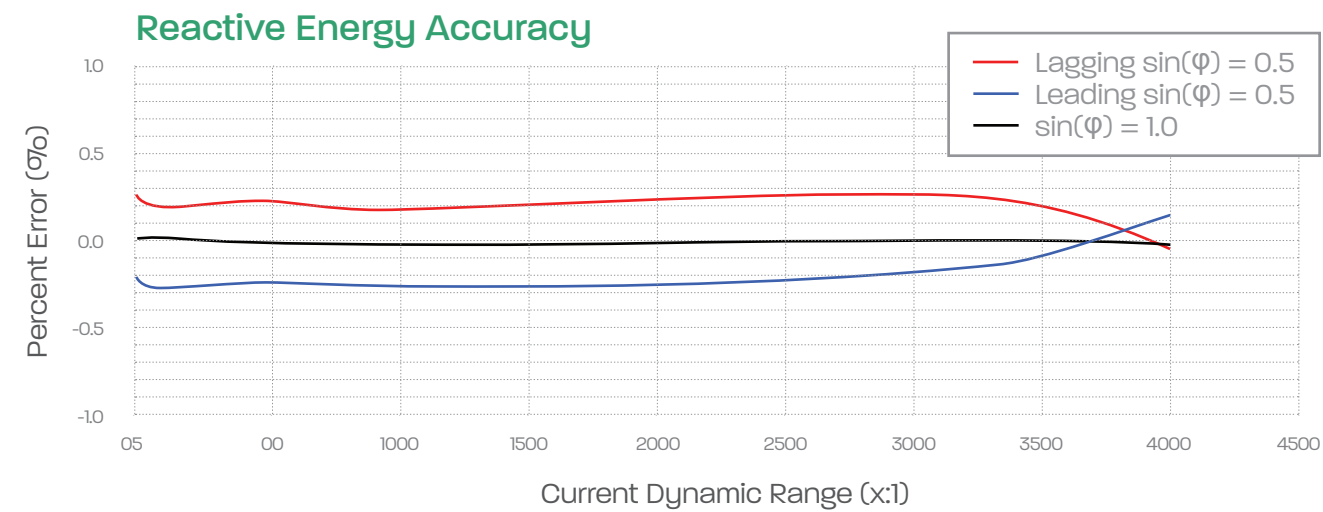
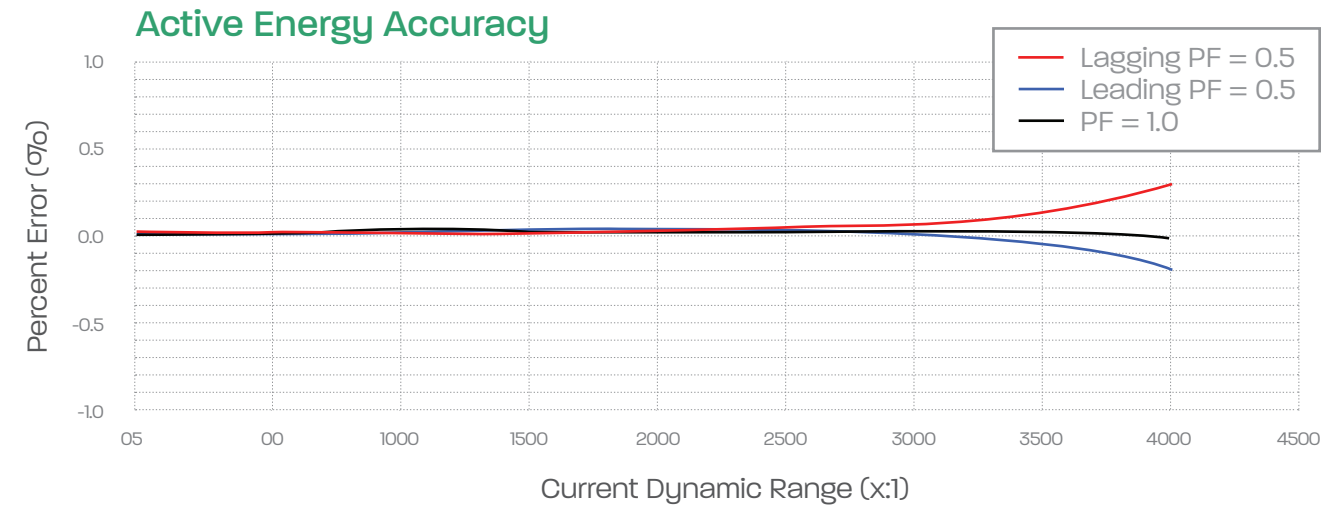

Part	CS5484	CS5480	CS5490	CS5467	CS5464	CS5463	CS5451A
ADC Converters	4	3	2	4	3	2	6
Current Sensor Options	Shunt/CT/Rogowski	Shunt/CT/Rogowski	Shunt/CT/Rogowski	Shunt/CT	Shunt/CT	Shunt/CT	Shunt/CT
Active Energy Accuracy	0.1% over 4000:1 dynamic range	0.1% over 4000:1 dynamic range	0.1% over 4000:1 dynamic range	0.1% over 1000:1 dynamic range	0.1% over 1000:1 dynamic range	0.1% over 1000:1 dynamic range	N/A
Reactive Energy Accuracy	0.1% over 4000:1 dynamic range	0.1% over 4000:1 dynamic range	0.1% over 4000:1 dynamic range	0.2% over 1000:1 dynamic range	0.2% over 1000:1 dynamic range	0.2% over 1000:1 dynamic range	N/A
I _{RMS} Accuracy	0.1% over 1000:1 dynamic range	0.1% over 1000:1 dynamic range	0.1% over 1000:1 dynamic range	0.1% over 1000:1 dynamic range	0.1% over 1000:1 dynamic range	0.2% over 1000:1 dynamic range	N/A
SNR	80dB	80dB	80dB	78dB	78dB	78dB	77dB
Serial Communication	SPI/ UART	SPI/ UART	UART	SPI	SPI	SPI	SPI
Digital Outputs	4x Configurable Outputs	3x Configurable Outputs	Single Configurable Output	Energy Pulses	Energy Pulses	Energy Pulses	-
V _{REF} Drift	25ppm/C	25ppm/C	25ppm/C	40ppm/C	40ppm/C	40ppm/C	25ppm/C
Input Voltage	3.3V	3.3V	3.3V	5V Analog 3.3/5V Digital	5V Analog 3.3/5V Digital	5V Analog 3.3/5V Digital	3V Analog 3V Digital
Power Consumption	< 13mW	< 13mW	< 13mW	25mW	25mW	21mW	23mW
Package	28 QFN	24 QFN	16 SOIC	28 SSOP	28 SSOP	24 SSOP	28 SSOP

Reference Design



CRD5490

The CRD5490 is an easy-to-use, small form-factor, power monitoring reference design. In a package the size of a business card, it gives designers access to all of the on-chip measurements of the CS5490 via an easy-to-use PC interface. User programming is NOT required for accurate measurements of line voltage, load current, line frequency, active power, reactive power, apparent power and power factor.

Plug one side into the wall for power and plug any load into the universal adapter, and within seconds you will be making real time measurements of power consumption. Power supply, shunt resistor, required isolation and shunt resistor are all included.

The CRD5490 is a great reference design for power supply monitoring, smart plugs, smart appliances or any other application that requires easy to use energy measurement in a very small form factor. Communication protocol, GUI, and MCU software source code are available from Cirrus Logic and can be tweaked for the specific needs of your system.

CDB5484-3P

The CDB5484-3P is an extensive tool designed to evaluate the functionality and performance of Cirrus Logic's 3-phase solution using 2x CS5484. It supports a Delta or wye configuration with either current transformers or Rogowski coils. With a total of 8 analog inputs, current and voltage for all three phases can be measured, as well as an additional current channel for neutral monitoring. Three-phase power calculations, clock synchronization and phase angle measurement functionality can all be evaluated on this easy to use development board. Intuitive GUI software provides easy and full access to the on-board CS5484 devices and the MCU. Onboard LEDs and LCD display enable standalone operation for extended testing. Getting started with a CDB enables fast and easy preliminary evaluation of Cirrus Logic's low cost three-phase solutions.

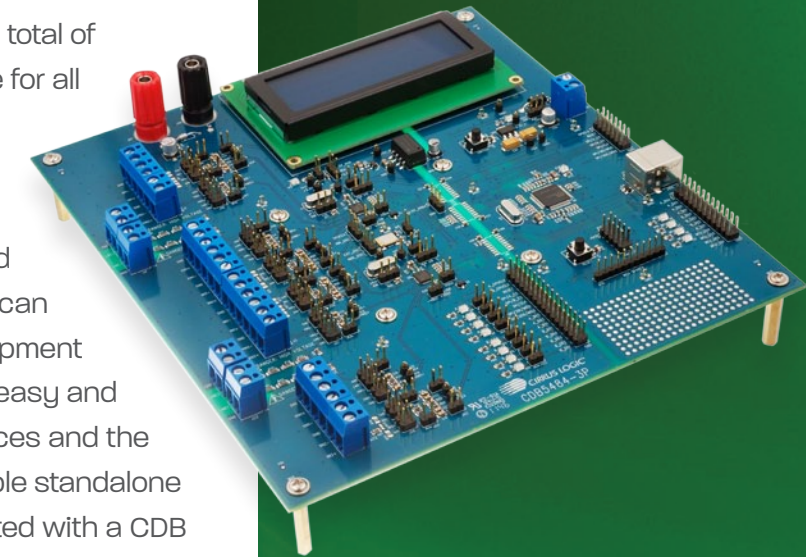

Development Boards

CDB5484/80/90U

The CDB5484/80/90U boards are designed to evaluate the functionality and performance of the CS5484/80/90 energy measurement IC family. Shunt resistors, current transformers or Rogowski coils can be connected to the analog inputs. Intuitive GUI software provides easy and full access to the on-board CS5484/80/90 device and MCU. On-board LEDs and LCD displays enable stand alone operation for extended testing. These CDBs enable fast and easy preliminary evaluation of Cirrus Logic's AFE products.

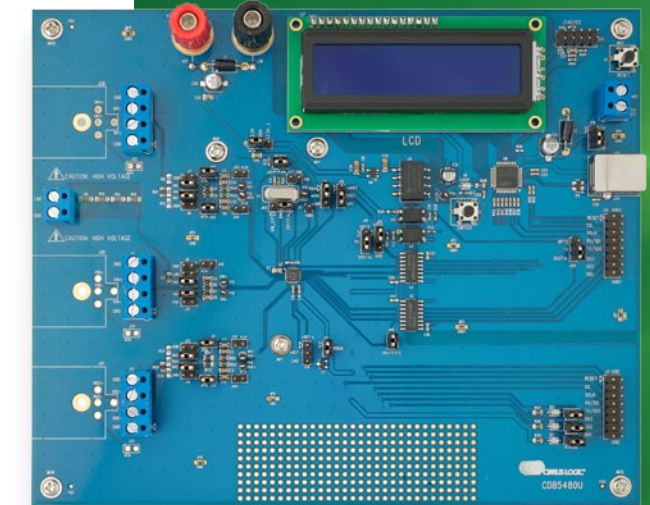



Cirrus Logic, Inc.

2901 Via Fortuna
Austin, Texas 78746
United States
T+1 512-851-4000
F+1 512-851-4977
Toll-Free +800-888-5016

Sales Support

North America +1 800-625-4084
Asia Pacific +852 2376-0801
Japan +81 (3) 5226-7757
Europe/UK +44 (90) 1628-891-300

www.cirrus.com

© 2012 Cirrus Logic, Inc. All rights reserved. Cirrus Logic, Cirrus, the Cirrus Logic logo designs, EXL Core, and the EXL Core logo design are trademarks of Cirrus Logic, Inc.

