



WM8524-6228-DT16-EV1

Example Configurations

DOC TYPE:	Example Configurations
BOARD REFERENCE:	WM8524-6228-DT16-EV1
BOARD TYPE:	Customer Standalone Board
WOLFSON DEVICE(S):	WM8524
DATE:	August 2009
DOC REVISION:	Rev 1.0

INTRODUCTION

The WM8524-6228-DT16-EV1 Customer Standalone Board provides a complete hardware platform for evaluation of the WM8524. The WM8524 Customer Standalone Board can also be connected directly to a processor board using flying wires or appropriate headers.

Configurations covered are listed below:

- DAC Playback to Line Out

This document should be used as a starting point for evaluation of WM8524 but it will not cover every possible configuration.

Assumptions:

1. The user is familiar with the WM8524-6228-DT16-EV1 board and that the board is configured correctly for the path of interest (see related documents below).

Related documents:

1. WM8524-6228-DT16-EV1_Schematic_Layout.pdf

TABLE OF CONTENTS

INTRODUCTION	1
TABLE OF CONTENTS	2
BOARD CONFIGURATION STAND-ALONE	3
CONNECTION DIAGRAM.....	3
I/O TABLE	4
SYSTEM BOARD CONFIGURATION	5
DAC PLAYBACK TO LINE OUT.....	5
APPLICATION SUPPORT.....	7
IMPORTANT NOTICE	8
ADDRESS:	8

BOARD CONFIGURATION STAND-ALONE

The WM8524 Customer Standalone Board can be used a stand-alone module for direct connection to a processor board via flying leads or dedicated headers. This section will detail important considerations and provide all information required to do this without risking damage to the device.

CONNECTION DIAGRAM

Figure 1 below shows the connections required to power-up and control the WM8524 Customer Standalone Board.

Please refer to Table 1 for further detail on external I/O connections.

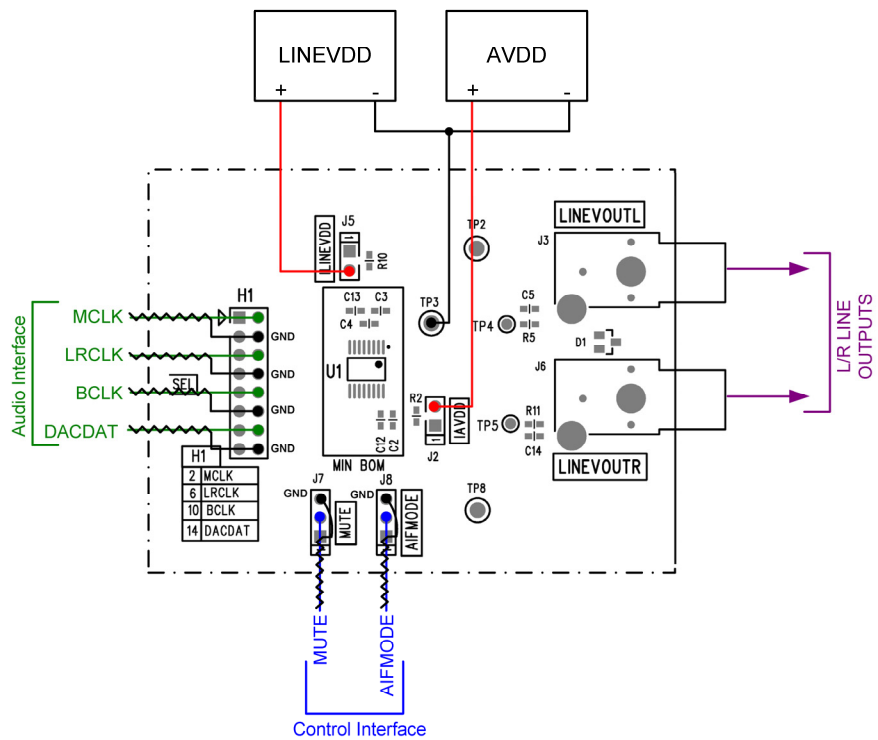

Figure 1 Stand-Alone Board Configuration

I/O TABLE

SIGNAL	BOARD REFERENCE	PART TO REMOVE	IMPORTANT NOTES		
Voltage Supplies					
AVDD	J2.2	R2	LINEVDD and AVDD must always be within 0.3V of each other and at 3.3V \pm 10%		
LINEVDD	J5.2	R10			
Ground					
AGND	TP3		Analogue grounds must always be within 0.3V of each other		
LINEGND	TP3				
Master Clock					
MCLK	H1.2	Jumper H1.1	Master clock	Referenced to LINEVDD level	
Audio Interface					
LRCLK	H1.6	Jumper H1.5	Digital audio interface left/right clock		
BCLK	H1.10	Jumper H1.9	Digital audio interface bit clock		
DACDAT	H1.14	Jumper H1.13	Digital audio interface data input		
MUTE	J7.2	Jumper J7.1	0 = Mute enabled 1 = Mute disabled		
AIFMODE	J8.2	Jumper J8.1	0 = 24-bit Left Justified 1 = 24-bit I ² S Z = 24-bit Right Justified		
Analogue Outputs					
LINEVOUTL	J3		Left line output		
LINEVOUTR	J6		Right line output		

Table 1 I/O Configuration

Table 1 above shows the points on the board where external stimuli can be connected, and the description of each pins function.

It also details the components that must be removed before external stimuli are connected to avoid bus contention.

SYSTEM BOARD CONFIGURATION

This section focuses on evaluation of the WM8524-6228-DT16-EV1 Customer Standalone Board. This system is the reference platform for measurement data contained in this document. Please note that only a limited number of usage modes will be covered.

DAC PLAYBACK TO LINE OUT

The following section details board configuration for DAC playback to line out.

BLOCK DIAGRAM

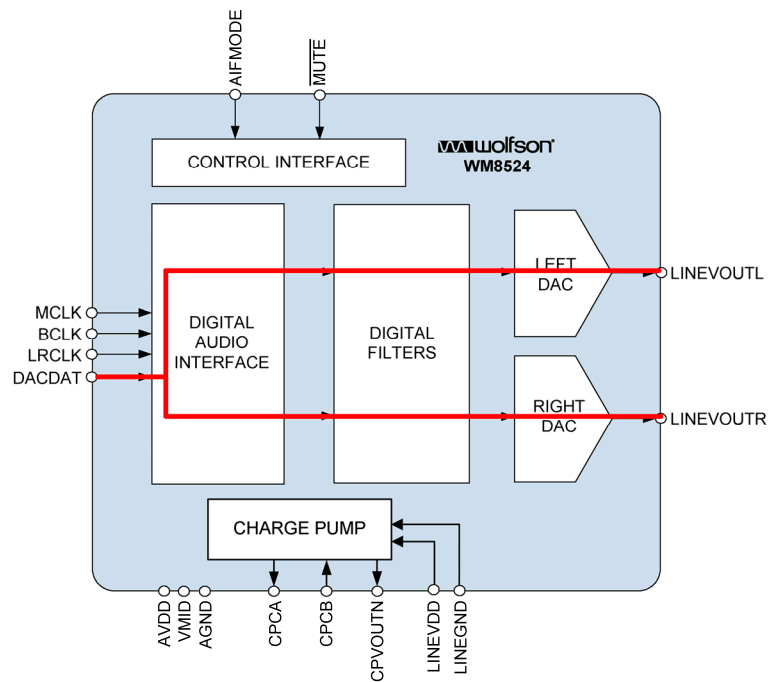

Figure 2 DAC Playback to Line Out

BOARD CONFIGURATION

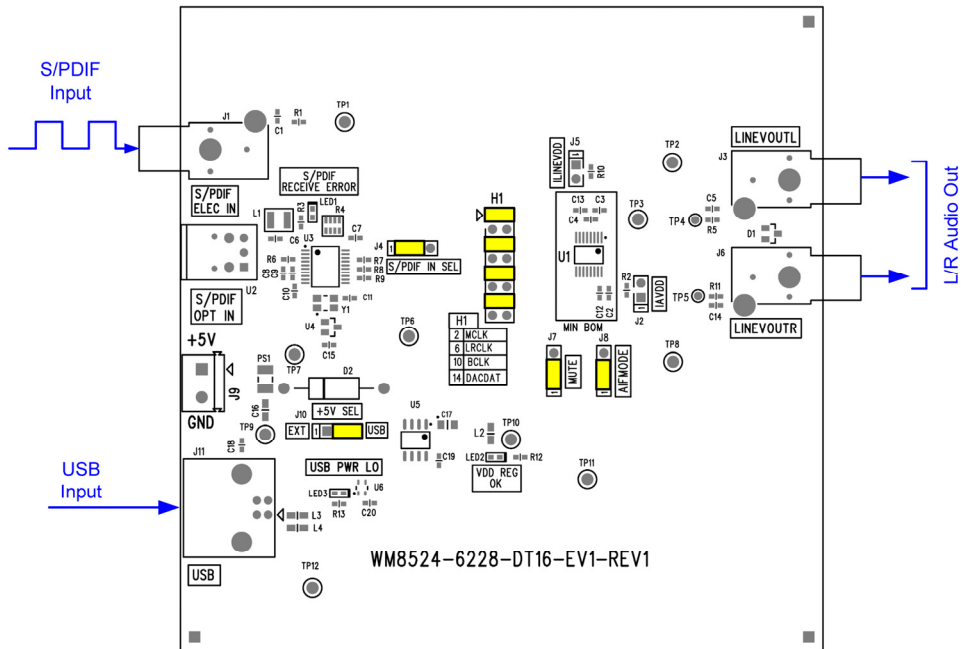

Figure 3 Board Configuration

APPLICATION SUPPORT

If you require more information or require technical support, please contact the Wolfson Microelectronics Applications group through the following channels:

Email: apps@wolfsonmicro.com
Telephone Apps: +44 (0) 131 272 7070
Fax: +44 (0) 131 272 7001
Mail: Applications Engineering at the address on the last page

or contact your local Wolfson representative.

Additional information may be made available on our web site at:

<http://www.wolfsonmicro.com>

IMPORTANT NOTICE

Wolfson Microelectronics plc ("Wolfson") products and services are sold subject to Wolfson's terms and conditions of sale, delivery and payment supplied at the time of order acknowledgement.

Wolfson warrants performance of its products to the specifications in effect at the date of shipment. Wolfson reserves the right to make changes to its products and specifications or to discontinue any product or service without notice. Customers should therefore obtain the latest version of relevant information from Wolfson to verify that the information is current.

Testing and other quality control techniques are utilised to the extent Wolfson deems necessary to support its warranty. Specific testing of all parameters of each device is not necessarily performed unless required by law or regulation.

In order to minimise risks associated with customer applications, the customer must use adequate design and operating safeguards to minimise inherent or procedural hazards. Wolfson is not liable for applications assistance or customer product design. The customer is solely responsible for its selection and use of Wolfson products. Wolfson is not liable for such selection or use nor for use of any circuitry other than circuitry entirely embodied in a Wolfson product.

Wolfson's products are not intended for use in life support systems, appliances, nuclear systems or systems where malfunction can reasonably be expected to result in personal injury, death or severe property or environmental damage. Any use of products by the customer for such purposes is at the customer's own risk.

Wolfson does not grant any licence (express or implied) under any patent right, copyright, mask work right or other intellectual property right of Wolfson covering or relating to any combination, machine, or process in which its products or services might be or are used. Any provision or publication of any third party's products or services does not constitute Wolfson's approval, licence, warranty or endorsement thereof. Any third party trade marks contained in this document belong to the respective third party owner.

Reproduction of information from Wolfson datasheets is permissible only if reproduction is without alteration and is accompanied by all associated copyright, proprietary and other notices (including this notice) and conditions. Wolfson is not liable for any unauthorised alteration of such information or for any reliance placed thereon.

Any representations made, warranties given, and/or liabilities accepted by any person which differ from those contained in this datasheet or in Wolfson's standard terms and conditions of sale, delivery and payment are made, given and/or accepted at that person's own risk. Wolfson is not liable for any such representations, warranties or liabilities or for any reliance placed thereon by any person.

ADDRESS:

Wolfson Microelectronics plc
Westfield House
26 Westfield Road
Edinburgh
EH11 2QB
United Kingdom

Tel :: +44 (0)131 272 7000

Fax :: +44 (0)131 272 7001

E-mail :: apps@wolfsonmicro.com