



Example Configurations

DOC TYPE:	EXAMPLE CONFIGURATIONS
BOARD REFERENCE:	WM8904-6201-CS36-M-REV1
BOARD TYPE:	Customer Mini Board
WOLFSON DEVICE(S):	WM8904
DATE:	August 2009
DOC REVISION:	Rev 1.0

INTRODUCTION

The WM8904-6201-CS36-M-REV1 Customer Mini Board is compatible with the 6201-EV1-REV2 customer evaluation board and together provide a complete hardware platform for evaluation of the WM8904. The WM8904 Customer Mini Board can also be used independently and connected directly to a processor board using flying field wires or appropriate headers. This document will cover both, but performance data will be based on the Wolfson system with 6201-EV1-REV2 mainboard. Configurations covered are listed below:

- DAC to Headphone playback
- IN1L/R to ADC Recording
- IN1L+2L / IN1R+2R to ADC Recording (differential input)
- IN3L/R to LINEOUTL/R (analogue bypass)
- IN3L/R to LINEOUTL/R (digital loopback)

This document should be used as a starting point for evaluation of WM8904 but it will not cover every possible configuration.

Assumptions:

1. The user is familiar with the 6201-EV1-REV2 main board and that the board is correctly configured for the path of interest (see related documents below)
2. The user has control of the WM8904 register settings, for example by installing Wolfson WISCE software.

Related documents:

1. WM8904 datasheet
2. WM8904-6201-CS36-M-REV1 Schematic and Layout.pdf
3. 6201-EV1-REV2 Schematic and Layout.pdf
4. WISCE Quick Start Guide.pdf

TABLE OF CONTENTS

INTRODUCTION	1
BOARD CONFIGURATION STAND-ALONE	3
CONNECTION DIAGRAM.....	3
I/O TABLE	4
SHORTING POINTS AND JUMPER LINKS TABLE	5
BOARD CONFIGURATION WITH 6201-EV1-REV2 MAIN BOARD	6
DAC TO HEADPHONE PLAYBACK.....	6
IN1L/R TO ADC RECORDING	9
IN1L+2L / IN1R+2R TO ADC RECORDING (DIFFERENTIAL MIC INPUT).....	11
IN3L/R TO LINEOUTL/R (ANALOGUE BYPASS)	13
IN3L/R TO LINEOUTL/R (DIGITAL LOOPBACK).....	16
APPLICATION SUPPORT	19
IMPORTANT NOTICE	20
ADDRESS:.....	20

BOARD CONFIGURATION STAND-ALONE

The WM8904 Customer Mini Board can be used a stand-alone module for direct connection to a processor board via flying leads or dedicated headers. This section will detail important considerations and provide all information required to do this without risking damage to the device.

CONNECTION DIAGRAM

Figure 1 below shows the connections required to power-up and control the WM8904 Customer Mini Board.

Please refer to the Table 1 for further detail on external I/O connections.

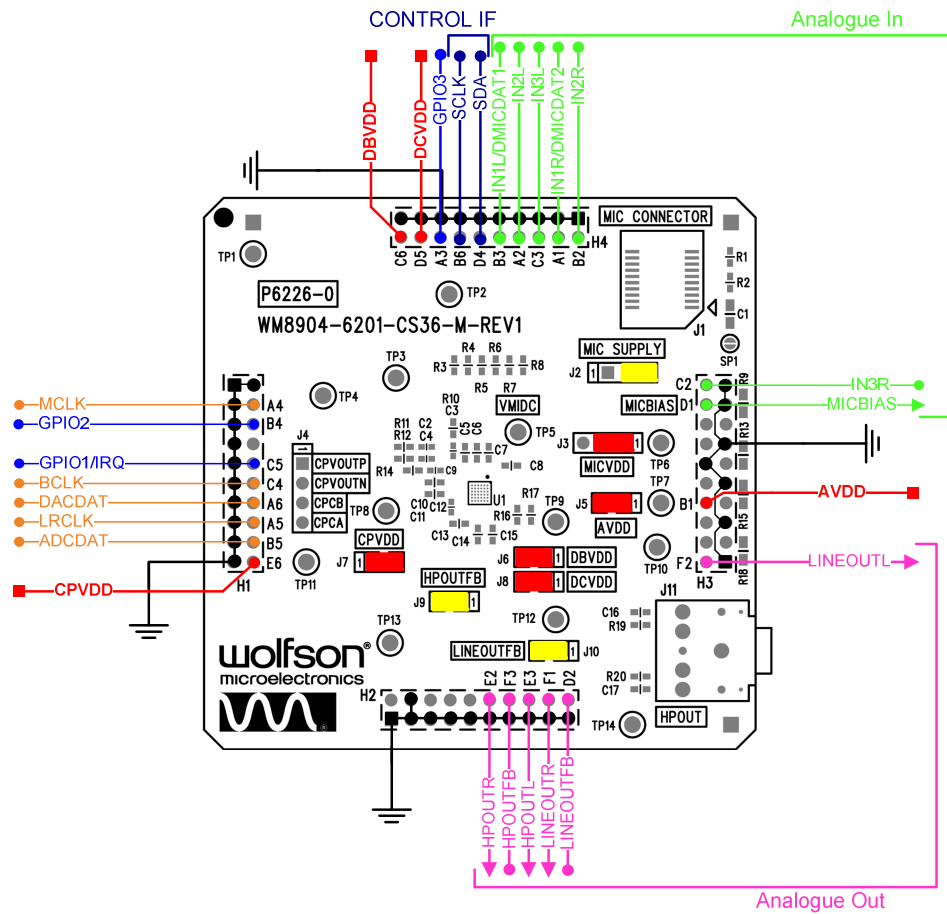

Figure 1 Stand-Alone Board Configuration

I/O TABLE

SIGNAL	BOARD REFERENCE	IMPORTANT NOTES
Voltage Supplies		
AVDD	H3: pin 8	AVDD = 1.71V to 2.0V
CPVDD	H1: pin 20	CPVDD = 1.71 to 2.0V
DCVDD	H4: pin 18	DCVDD = 0.95V to 1.98V
DBVDD	H4: pin 20	DBVDD = 1.42V to 3.6V
MICVDD	J5, TP10	MICVDD=1.71 to 3.6V , connected by default to AVDD, can also be supplied to pin 2 of J5
Ground		
DGND	Common Ground	Analogue and digital grounds must always be within 0.3V of each other
AGND		
CPGND		
Control Interface		
SDA	H4: pin 12	Both control interface signals should swing between DGND and DBVDD
SCLK	H4: pin 14	
Master Clock		
MCLK	H1: pin 4	Signal should swing between DGND and DBVDD
Digital I/O and Audio Interface		
GPI01/IRQ	H1: pin 10	Signals should swing between DGND and DBVDD
GPI02	H1: pin 6	
GPI03	H4: pin 16	
BCLK/GPI04	H1: pin 12	
DACDAT	H1: pin 14	
LRCLK	H1: pin 16	
ADCDAT	H1: pin 18	
Digital / Analogue Inputs		
IN3R	H3: pin 20	Observe maximum input levels as per WM8904 datasheet
IN2R	H4: pin 2	
IN1R/DMICDAT2	H4: pin 4	
IN3L	H4: pin 6	
IN2L	H4: pin 8	
IN1L/DMICDAT1	H4: pin 10	
MICBIAS	H3: pin 18	Analogue microphone bias voltage output
Analogue Outputs		
HPOUTR	H2: pin 12	Ground referenced headphone output
HPOUTL	H2: pin 16	
HPOUTFB	H2: pin 14	HP reference pin, recommended to be connected to the common ground at headphone connector
LINOUTR	H2: pin 18	Ground referenced line output
LINOUTL	H3: pin 2	
LINOUTFB	H2: pin 20	LINE reference pin, recommended to be connected to the common ground at line output connector.
Charge Pump and VMID		
CPVOUTP	J7: pin 2	Charge Pump and VMIDC test points
CPVOUTN	J7: pin 1	
CPCA	J7: pin 4	
CPCB	J7: pin 3	
VMIDC	TP6	

Table 1 I/O Configuration

SHORTING POINTS AND JUMPER LINKS TABLE

REFERENCE	FUNCTION	
SP1	Short this pin to be able to use the onboard MIC connector. If shorted this links pin 1 of the MIC connector to LINPUT2 of the device	
J5	AVDD	These jumpers link the relevant pins on the DUT to the different supply voltages. To supply different voltages disconnect the relevant jumper link and apply the chosen voltage directly to pin 2 of the relevant jumper.
J6	DBVDD	
J7	CPVDD	
J8	DCVDD	
J9	HPOUTFB	These jumper links are set by default and connect the headphone and lineout reference to common ground.
J10	LINEOUTFB	
J2	MIC Supply	Choose between MICBIAS and DBVDD for the MIC supply. Default is MICBIAS for analogue microphone.
J3	MICVDD	MICVDD by default is linked to AVDD (pin 1-2) alternatively it can be externally supplied to pin 2 (pin 3 is GND)

Table 2 Shorting Points and Jumper Links Table

BOARD CONFIGURATION

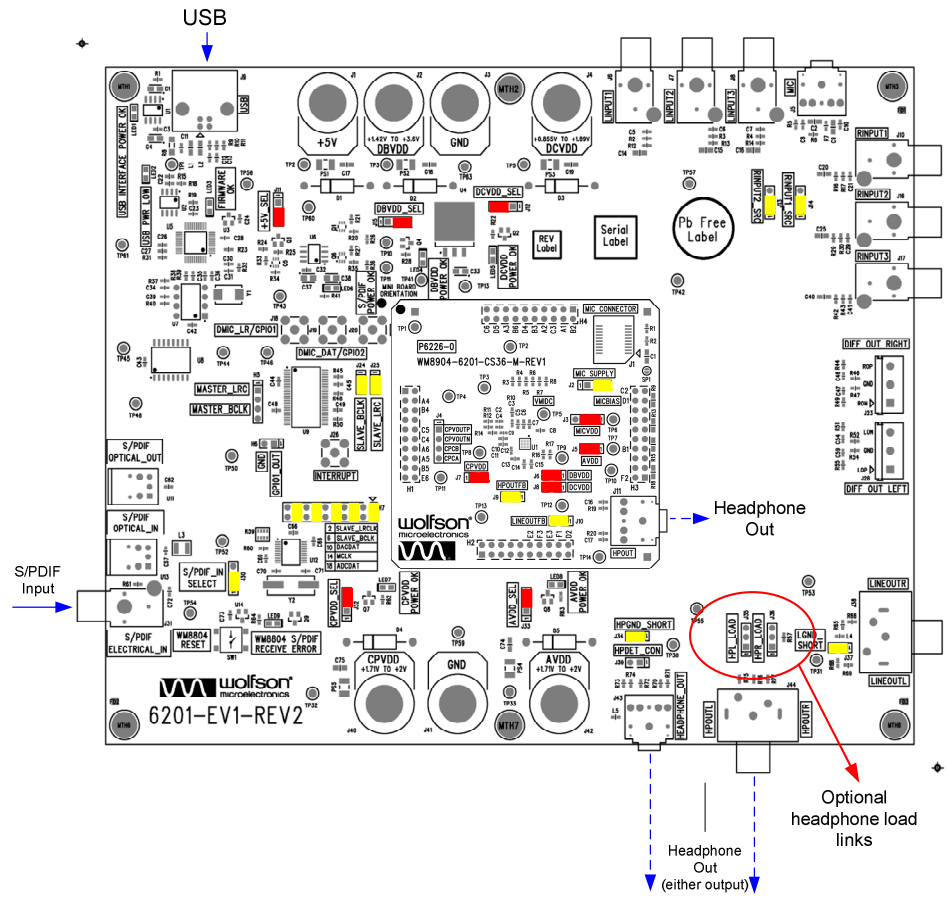

Figure 3 Board Configuration DAC to HPOUTL/R

REGISTER SETTINGS

Register settings provided below are the typical sequence to configure the desired path and have not in any way been optimised.

REG INDEX	DATA VALUE	COMMENT
0x00	0x0000	SW Reset
0x6C	0x0100	WSEQ_ENA=1, WSEQ_WRITE_INDEX=0_0000
0x6F	0x0100	WSEQ_ABORT=0, WSEQ_START=1, WSEQ_START_INDEX=00_0000
0x14	0x845E	TOCLK_RATE_DIV16=0, TOCLK_RATE_X4=0, SR_MODE=0, MCLK_DIV=0 (Required for MMCs: SGY, KRT see erratum CE000546)
0x39	0x0039	HPOUTL_MUTE=0, HPOUT_VU=0, HPOUTLZC=0, HPOUTL_VOL=11_1001
0x3A	0x00B9	HPOUTR_MUTE=0, HPOUT_VU=1, HPOUTRZC=0, HPOUTR_VOL=11_1001
0x21	0x0000	DAC_MONO=0, DAC_SB_FILTER=0, DAC_MUTERATE=0, DAC_UNMUTE_RAMP=0, DAC_OSR128=0, DAC_MUTE=0, DEEMPH=00
0x68	0x0005	CP_DYN_PWR=1

Table 3 Register Settings DAC to HPOUTL/R

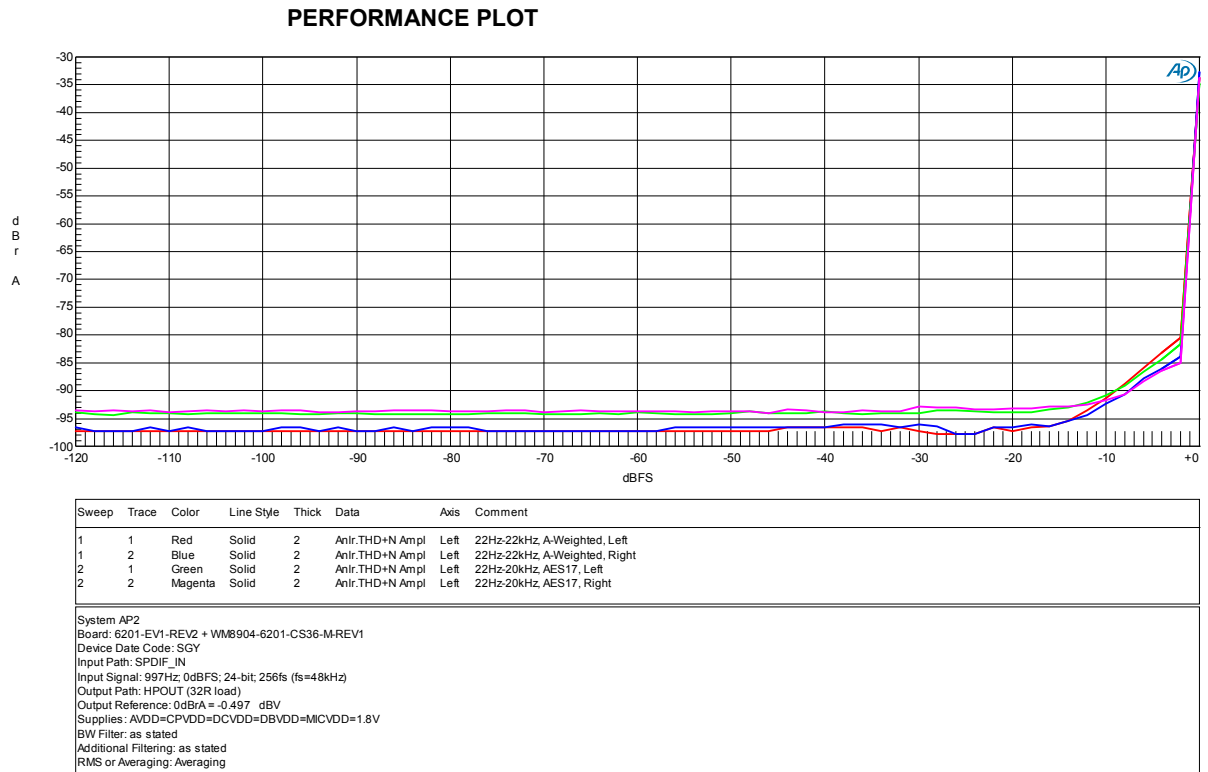

Figure 4 Performance Plot DAC to HPOUTL/R

IN1L/R TO ADC RECORDING

The following section details the configuration for IN1L/R to ADC recording. For board configuration, please refer to Figure 6.

BLOCK DIAGRAM

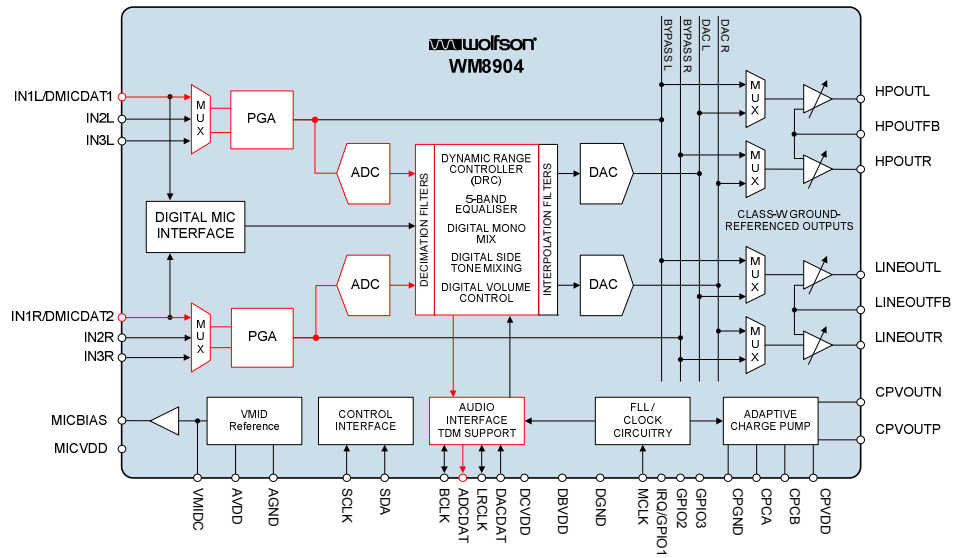

Figure 5 Path Diagram IN1L/R to ADC

BOARD CONFIGURATION

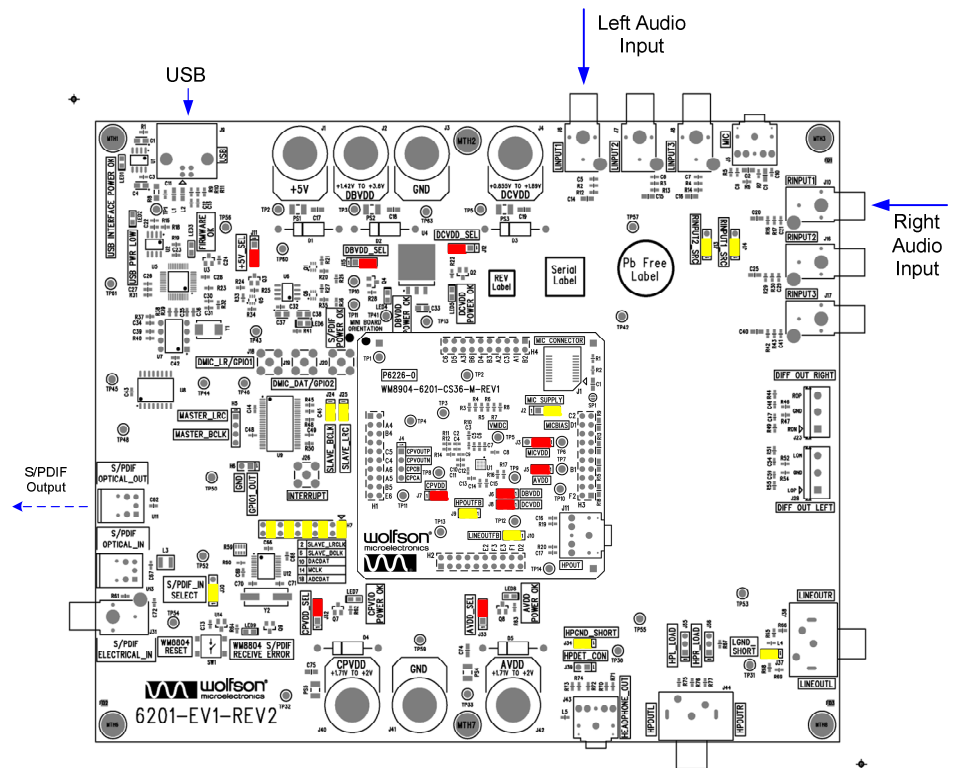

Figure 6 Board Configuration IN1L/R to ADC

REGISTER SETTINGS

Register settings provided below are simply the minimum requirement to configure the desired path and have not in any way been optimised.

REG INDEX	DATA VALUE	COMMENT
0x00	0x0000	SW Reset
0x04	0x0009	POBCTRL=0, ISEL=10, STARTUP_BIAS_ENA=0, BIAS_ENA=1
0x05	0x0043	VMID_BUF_ENA=1, VMID_RES=01, VMID_ENA=1
0x14	0x845E	TOCLK_RATE_DIV16=0, TOCLK_RATE_X4=0, SR_MODE=0, MCLK_DIV=0 (Required for MMCs: SGY, KRT see erratum CE000546)
0x0C	0x0003	INL_ENA=1, INR_ENA=1
0x12	0x0003	DACL_ENA=0, DACR_ENA=0, ADCL_ENA=1, ADCR_ENA=1
0x2C	0x0005	LINMUTE=0, LIN_VOL=0_0101
0x2D	0x0005	RINMUTE=0, RIN_VOL=0_0101

Table 4 Register Settings IN1L/R to ADC

PERFORMANCE PLOT

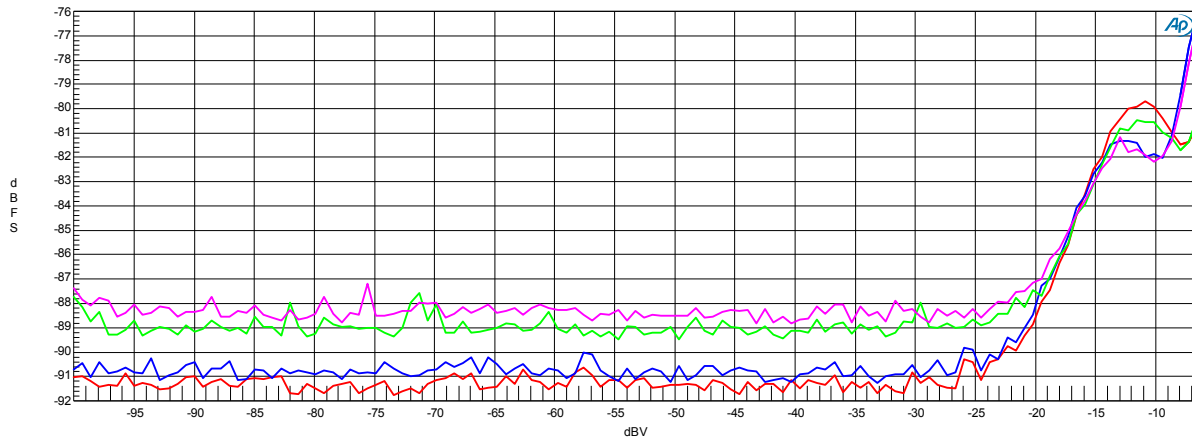

Sweep	Trace	Color	Line Style	Thick	Data	Axis	Comment
1	1	Red	Solid	2	DSP Anlr.THD+N Ampl A	Left	22Hz-20kHz, A-Weighted, Left
1	2	Blue	Solid	2	DSP Anlr.THD+N Ampl B	Left	22Hz-20kHz, A-Weighted, Right
2	1	Green	Solid	2	DSP Anlr.THD+N Ampl A	Left	22Hz-22kHz, Left
2	2	Magenta	Solid	2	DSP Anlr.THD+N Ampl B	Left	22Hz-22kHz, Right

Test System: AP2
 Board: 6201-EV1-REV2 + WM8904-6201-CS36-REV1
 Device Date Code: SGY
 Input Path: L/RIN/PUT1
 Input Signal: 0.997kHz
 Output Path: SPDFIF_OUT
 Output Signal: 24 bit 48kHz (256fs)
 Supplies: AVDD=CPVDD=DVCCDD=BBVDD=MICVDD=1.8V
 BW Filtering: as stated
 Additional Filtering Type: as stated
 RMS or Averaging: RMS

Figure 7 Performance Plot IN1L/R to ADC

IN1L+2L / IN1R+2R TO ADC RECORDING (DIFFERENTIAL MIC INPUT)

The following section details the configuration for recording from a differential microphone input (IN1L+R / IN1R+2R to ADC). For board configuration, please refer to Figure 6.

BLOCK DIAGRAM

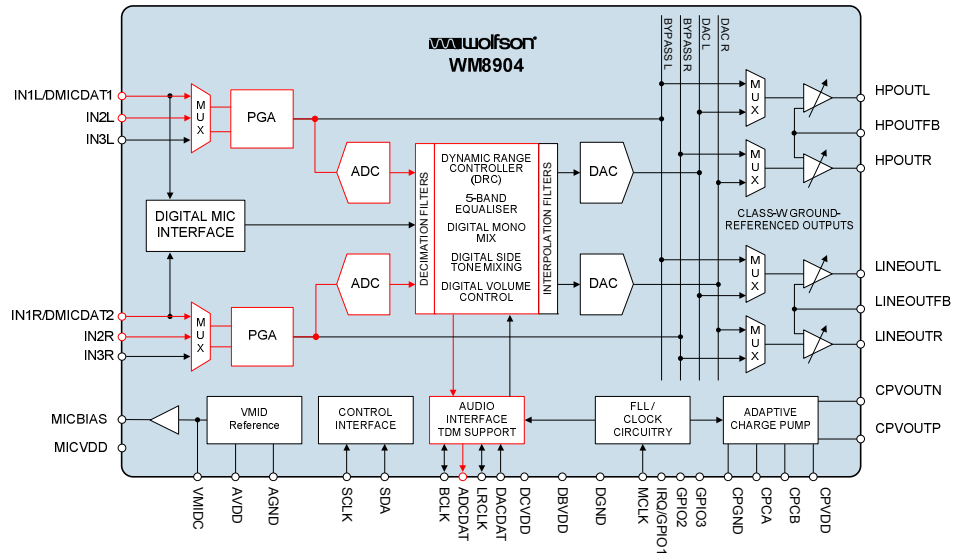

Figure 8 Path Path Diagram IN1L+2L / IN1R+2R to ADC

BOARD CONFIGURATION

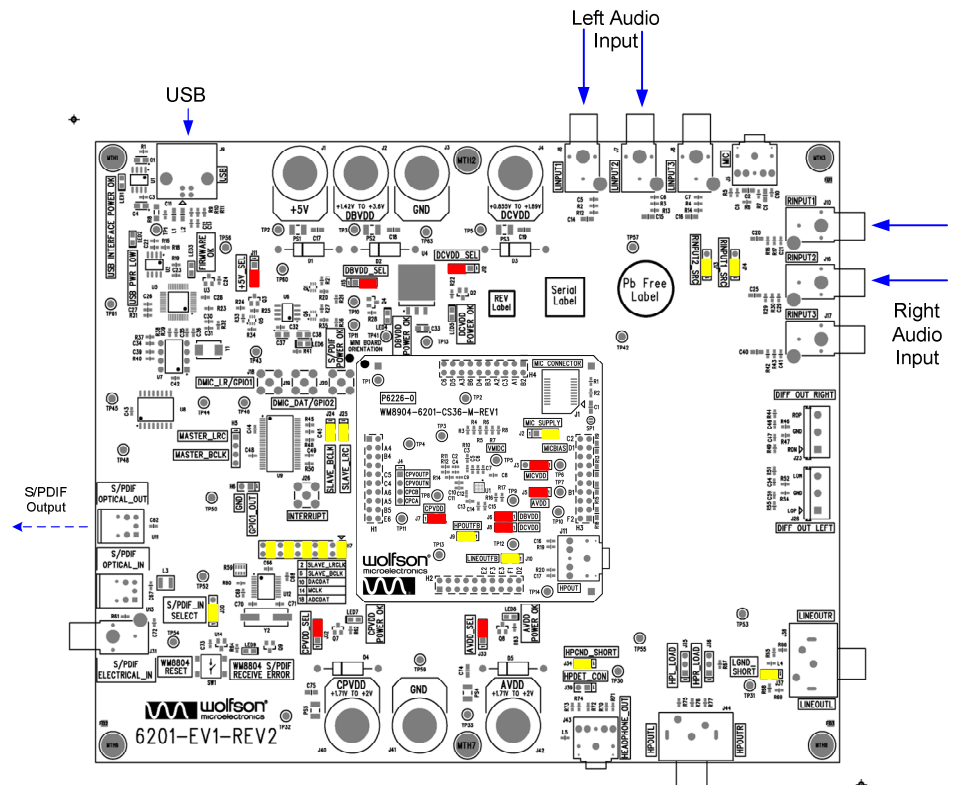

Figure 9 Board Configuration IN1L+2L / IN1R+2R to ADC

REGISTER SETTINGS

Register settings provided below are the typical sequence to configure the desired path and have not in any way been optimised.

REG INDEX	DATA VALUE	COMMENT
0x00	0x0000	SW Reset
0x04	0x0019	POBCTRL=1, ISEL=10, STARTUP_BIAS_ENA=0, BIAS_ENA=1
0x05	0x0043	VMID_BUF_ENA=1, VMID_RES=01, VMID_ENA=1
0x14	0x845E	TOCLK_RATE_DIV16=0, TOCLK_RATE_X4=0, SR_MODE=0, MCLK_DIV=0 (Required for MMCs: SGY, KRT see erratum CE000546)
0x0C	0x0003	INL_ENA=1, INR_ENA=1
0x12	0x0003	DACL_ENA=0, DACR_ENA=0, ADCL_ENA=1, ADCR_ENA=1
0x2C	0x001F	LINMUTE=0, LIN_VOL=1_1111
0x2D	0x001F	RINMUTE=0, RIN_VOL=1_1111
0x2E	0x0046	INL_CM_ENA=1, L_IP_SEL_N=00, L_IP_SEL_P=01, L_MODE=10
0x2F	0x0046	INR_CM_ENA=1, R_IP_SEL_N=00, R_IP_SEL_P=01, R_MODE=10

Table 5 IN1L+2L / IN1R+2R to ADC (differential MIC input)

PERFORMANCE PLOT

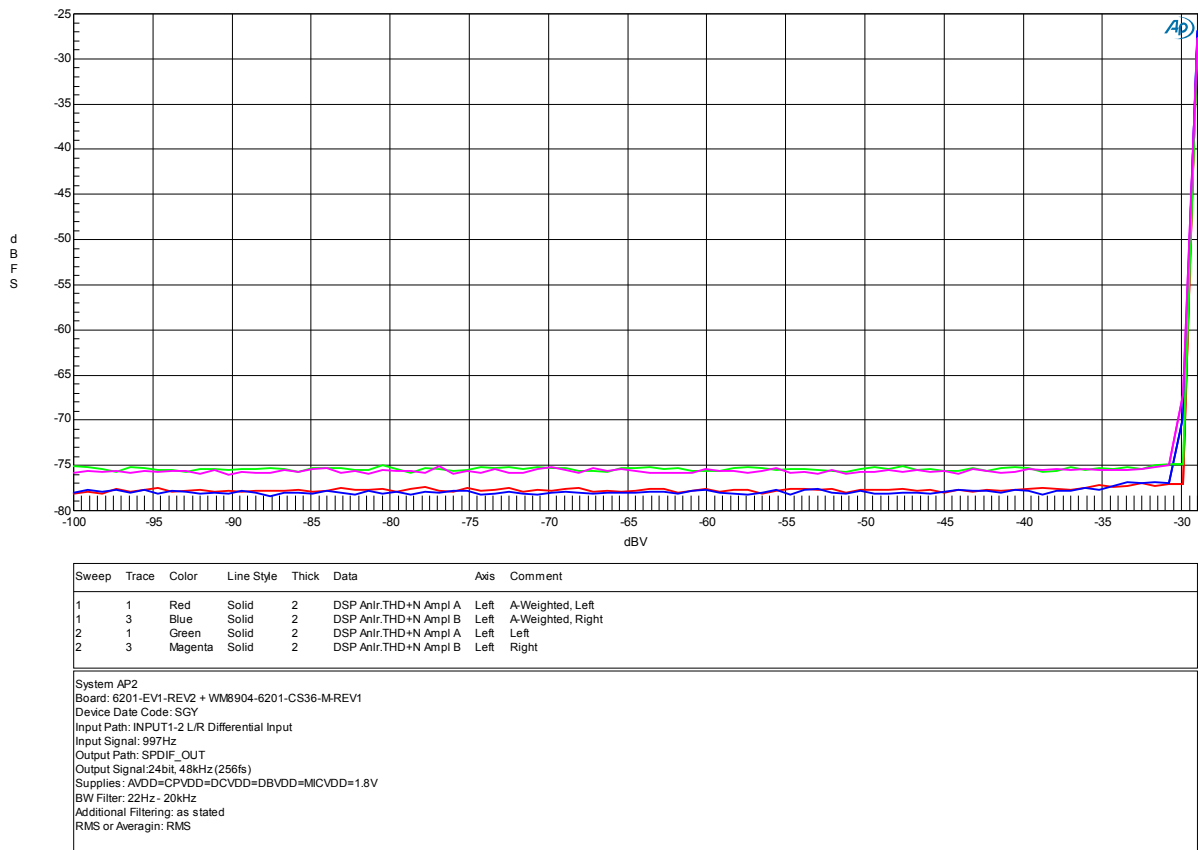

Figure 10 Performance Plot IN1L+2L / IN1R+2R to ADC (differential MIC)

IN3L/R TO LINEOUTL/R (ANALOGUE BYPASS)

The following section details the configuration of an analogue bypass from IN3L/R to LINEOUTL/R. For board configuration, please refer to Figure 12.

BLOCK DIAGRAM

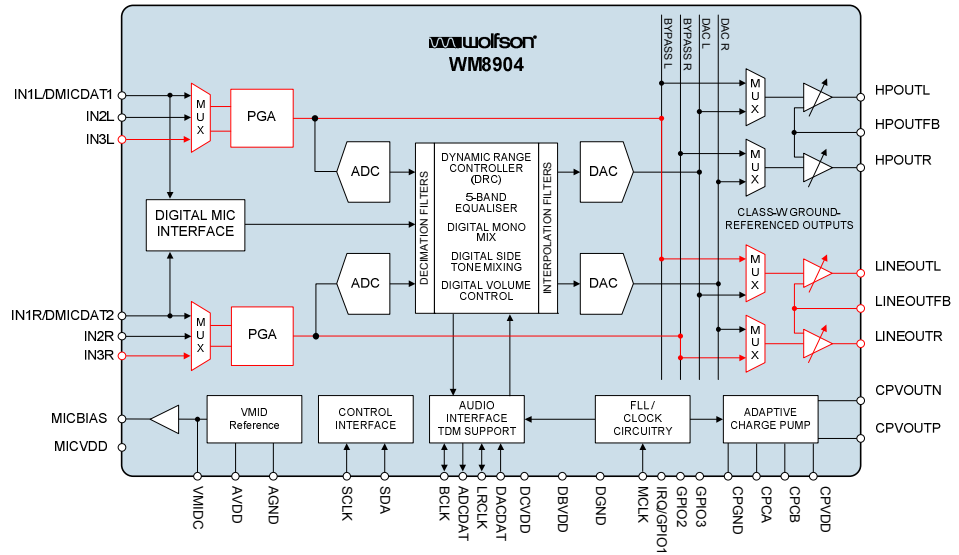

Figure 11 Path Diagram IN3L/R to LINEOUTL/R

BOARD CONFIGURATION

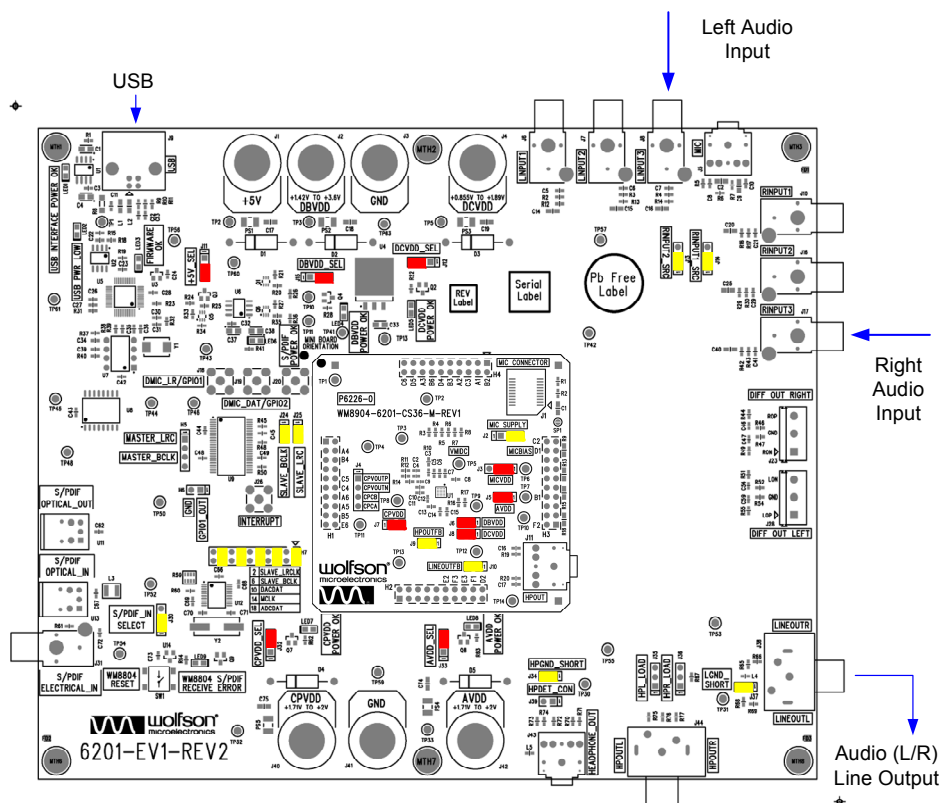

Figure 12 Board Configuration IN3L/R to LINEOUTL/R

REGISTER SETTINGS

Register settings provided below are simply the minimum requirement to configure the desired path and have not in any way been optimised.

REG INDEX	DATA VALUE	COMMENT
0x00	0x0000	SW Reset
0x04	0x0009	POBCTRL=0, ISEL=10, STARTUP_BIAS_ENA=0, BIAS_ENA=1
0x05	0x0043	VMID_BUF_ENA=1, VMID_RES=01, VMID_ENA=1
0x0C	0x0003	INL_ENA=1, INR_ENA=1
0x0F	0x0003	LINEOUTL_PGA_ENA=1, LINEOUTR_PGA_ENA=1
0x2E	0x0024	INL_CM_ENA=0, L_IP_SEL_N=10, L_IP_SEL_P=01, L_MODE=00
0x2F	0x0024	INR_CM_ENA=0, R_IP_SEL_N=10, R_IP_SEL_P=01, R_MODE=00
0x2C	0x0005	LINMUTE=0, LIN_VOL=0_0101
0x2D	0x0005	RINMUTE=0, RIN_VOL=0_0101
0x3D	0x0003	HPL_BYP_ENA=0, HPR_BYP_ENA=0, LINEOUTL_BYP_ENA=1, LINEOUTR_BYP_ENA=1
0x5E	0x00FF	LINEOUTL_RMV_SHORT=1, LINEOUTL_ENA_OUTP=1, LINEOUTL_ENA_DLY=1, LINEOUTL_ENA=1, LINEOUTR_RMV_SHORT=1, LINEOUTR_ENA_OUTP=1, LINEOUTR_ENA_DLY=1, LINEOUTR_ENA=1
0x62	0x0001	CP_ENA=1

Table 6 Register Settings IN3L/R to LINEOUTL/R

PERFORMANCE PLOT

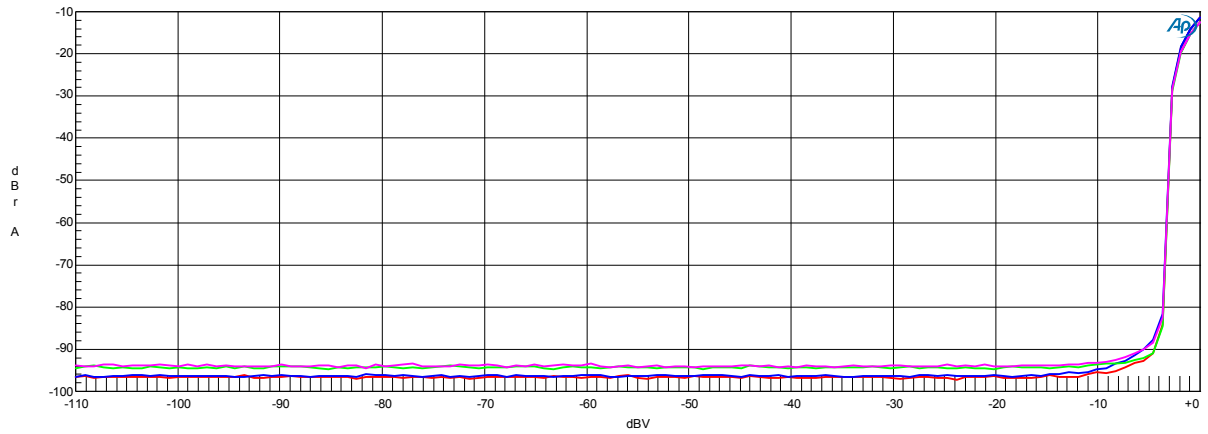

Sweep	Trace	Color	Line Style	Thick	Data	Axis	Comment
1	1	Red	Solid	2	Anlr.THD+N Ampl	Left	22Hz - 22kHz, A-Weighting, Left
1	2	Blue	Solid	2	Anlr.THD+N Ampl	Left	22Hz - 22kHz, A-Weighting, Right
2	1	Green	Solid	2	Anlr.THD+N Ampl	Left	22Hz - 20kHz AES17, Left
2	2	Magenta	Solid	2	Anlr.THD+N Ampl	Left	22Hz - 20kHz AES17, Right

System = AP2
 Board: 6201-EV1-REV2 + WM8904-6201-CS36-REV1
 Device Datecode: SGY
 Input Signal: 1kHz
 Reference Levels: 0dB_{RA} = -0.860 dBV
 Supplies: AVDD=CPVDD=DCVDD=1.8V
 Input Signal Path: L:RINPUT3
 Output Signal Path: L:ROUT (Lineout)
 BW Filtering: as stated
 Additional Filtering Type: as stated
 RMS or Averaging = Average

Figure 13 Performance Plot (IN3L/R to LINEOUTL/R)

IN3L/R TO LINEOUTL/R (DIGITAL LOOPBACK)

The following section details the configuration for the digital loopback path.

BLOCK DIAGRAM

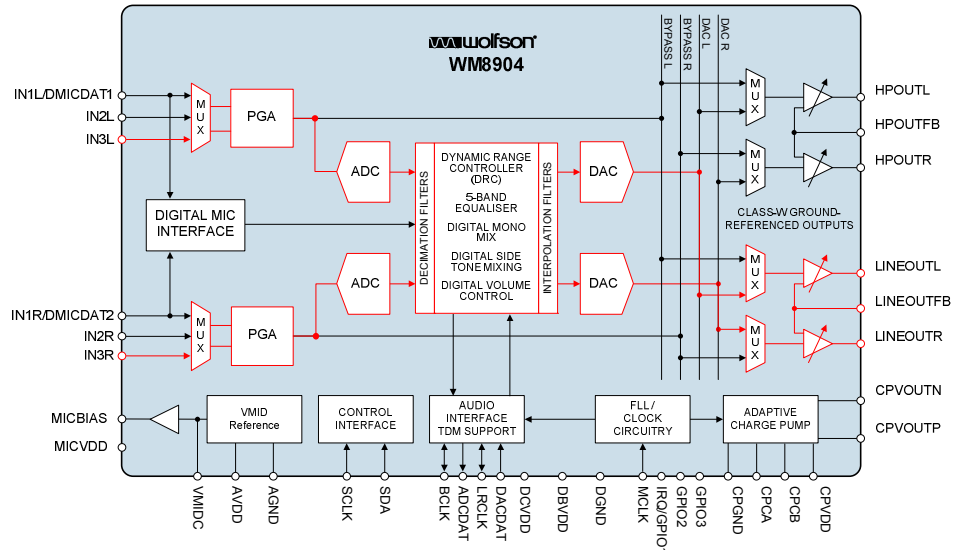

Figure 14 Path Diagram IN3L/R to LINEOUTL/R (digital loopback)

BOARD CONFIGURATION

The board configuration for this path is equivalent to the one used for the analogue bypass. See Figure 12 for reference.

REGISTER SETTINGS

Register settings provided below are simply the minimum requirement to configure the desired path and have not in any way been optimised.

REG INDEX	DATA VALUE	COMMENT
0x00	0x0000	SW Reset
0x04	0x0019	POBCTRL=1, ISEL=10, STARTUP_BIAS_ENA=0, BIAS_ENA=1
0x05	0x0043	VMID_BUF_ENA=1, VMID_RES=01, VMID_ENA=1
0x14	0x845E	TOCLK_RATE_DIV16=0, TOCLK_RATE_X4=0, SR_MODE=0, MCLK_DIV=0 (Required for MMCs: SGY, KRT see erratum CE000546)
0x0C	0x0003	INL_ENA=1, INR_ENA=1
0x0F	0x0003	LINEOUTL_PGA_ENA=1, LINEOUTR_PGA_ENA=1
0x12	0x000F	DACL_ENA=1, DACR_ENA=1, ADCL_ENA=1, ADCR_ENA=1
0x18	0x0150	DACL_DATINV=0, DACR_DATINV=0, DAC_BOOST=0, LOOPBACK=1, AIFADCL_SRC=0, AIFADCR_SRC=1, AIFDACL_SRC=0, AIFDACR_SRC=1, ADC_COMP=0, ADC_COMPMODE=0, DAC_COMP=0, DAC_COMPMODE=0
0x21	0x0000	DAC_MONO=0, DAC_SB_FILTER=0, DAC_MUTERATE=0, DAC_UNMUTE_RAMP=0, DAC_OSR128=0, DAC_MUTE=0, DEEMPH=00
0x2E	0x0024	INL_CM_ENA=0, L_IP_SEL_N=10, L_IP_SEL_P=01, L_MODE=00
0x2F	0x0024	INR_CM_ENA=0, R_IP_SEL_N=10, R_IP_SEL_P=01, R_MODE=00
0x2C	0x0005	LINMUTE=0, LIN_VOL=0_0101
0x2D	0x0005	RINMUTE=0, RIN_VOL=0_0101
0x5E	0x00FF	LINEOUTL_RMV_SHORT=1, LINEOUTL_ENA_OUTP=1, LINEOUTL_ENA_DLY=1, LINEOUTL_ENA=1, LINEOUTR_RMV_SHORT=1, LINEOUTR_ENA_OUTP=1, LINEOUTR_ENA_DLY=1, LINEOUTR_ENA=1
0x68	0x0005	CP_DYN_PWR=1
0x62	0x0001	CP_ENA=1

Table 7 Register Settings IN3L/R to LINEOUTL/R (digital loopback)

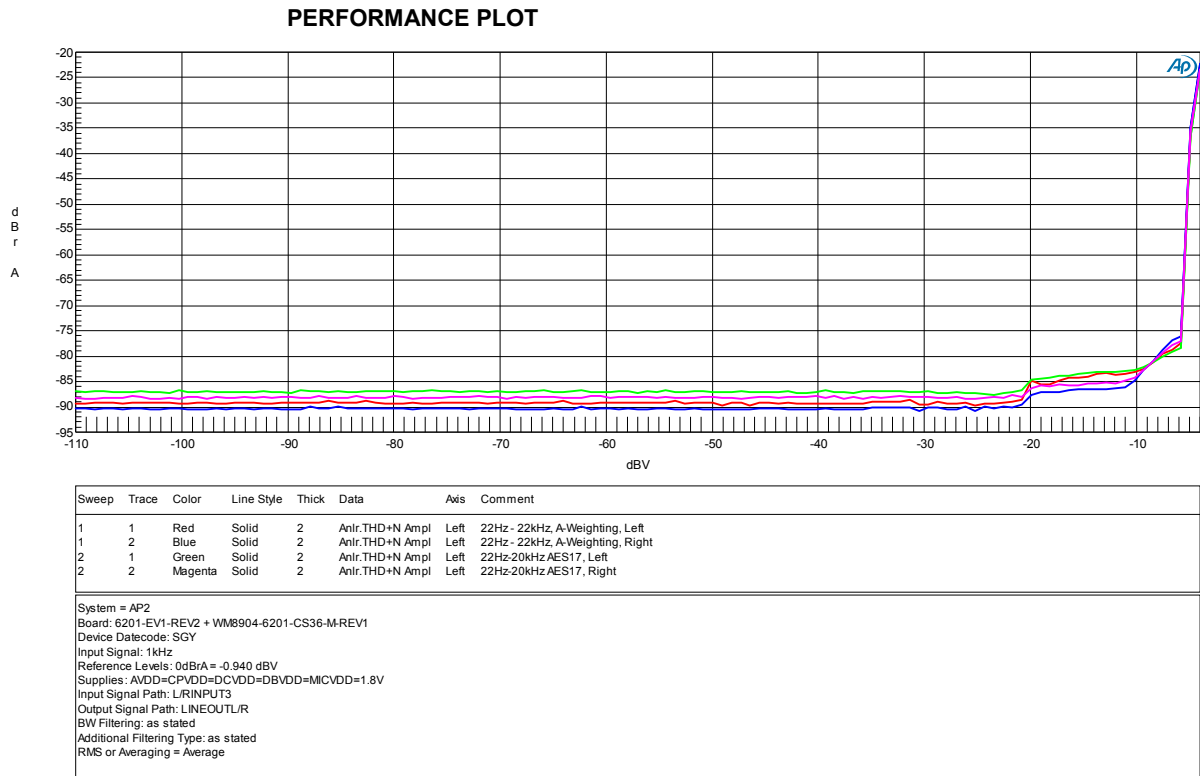

Figure 15 Performance Plot IN3L/R to LINEOUTL/R (digital loopback)

APPLICATION SUPPORT

If you require more information or require technical support, please contact the Wolfson Microelectronics Applications group through the following channels:

Email: apps@wolfsonmicro.com
Telephone Apps: +44 (0) 131 272 7070
Fax: +44 (0) 131 272 7001
Mail: Applications Engineering at the address on the last page

or contact your local Wolfson representative.

Additional information may be made available on our web site at:

<http://www.wolfsonmicro.com>

IMPORTANT NOTICE

Wolfson Microelectronics plc ("Wolfson") products and services are sold subject to Wolfson's terms and conditions of sale, delivery and payment supplied at the time of order acknowledgement.

Wolfson warrants performance of its products to the specifications in effect at the date of shipment. Wolfson reserves the right to make changes to its products and specifications or to discontinue any product or service without notice. Customers should therefore obtain the latest version of relevant information from Wolfson to verify that the information is current.

Testing and other quality control techniques are utilised to the extent Wolfson deems necessary to support its warranty. Specific testing of all parameters of each device is not necessarily performed unless required by law or regulation.

In order to minimise risks associated with customer applications, the customer must use adequate design and operating safeguards to minimise inherent or procedural hazards. Wolfson is not liable for applications assistance or customer product design. The customer is solely responsible for its selection and use of Wolfson products. Wolfson is not liable for such selection or use nor for use of any circuitry other than circuitry entirely embodied in a Wolfson product.

Wolfson's products are not intended for use in life support systems, appliances, nuclear systems or systems where malfunction can reasonably be expected to result in personal injury, death or severe property or environmental damage. Any use of products by the customer for such purposes is at the customer's own risk.

Wolfson does not grant any licence (express or implied) under any patent right, copyright, mask work right or other intellectual property right of Wolfson covering or relating to any combination, machine, or process in which its products or services might be or are used. Any provision or publication of any third party's products or services does not constitute Wolfson's approval, licence, warranty or endorsement thereof. Any third party trade marks contained in this document belong to the respective third party owner.

Reproduction of information from Wolfson datasheets is permissible only if reproduction is without alteration and is accompanied by all associated copyright, proprietary and other notices (including this notice) and conditions. Wolfson is not liable for any unauthorised alteration of such information or for any reliance placed thereon.

Any representations made, warranties given, and/or liabilities accepted by any person which differ from those contained in this datasheet or in Wolfson's standard terms and conditions of sale, delivery and payment are made, given and/or accepted at that person's own risk. Wolfson is not liable for any such representations, warranties or liabilities or for any reliance placed thereon by any person.

ADDRESS:

Wolfson Microelectronics plc
Westfield House
26 Westfield Road
Edinburgh
EH11 2QB
United Kingdom

Tel :: +44 (0)131 272 7000

Fax :: +44 (0)131 272 7001

E-mail :: apps@wolfsonmicro.com