

DOC TYPE:	SCHEMATIC AND LAYOUT
BOARD REFERENCE:	WM8918-6201-FL32-M-REV1
BOARD TYPE:	Customer Mini
WOLFSON DEVICE(S):	WM8918
DATE:	June 2010
DOC REVISION:	Rev 1.0

SCHEMATIC

Sheet 1: WM8918

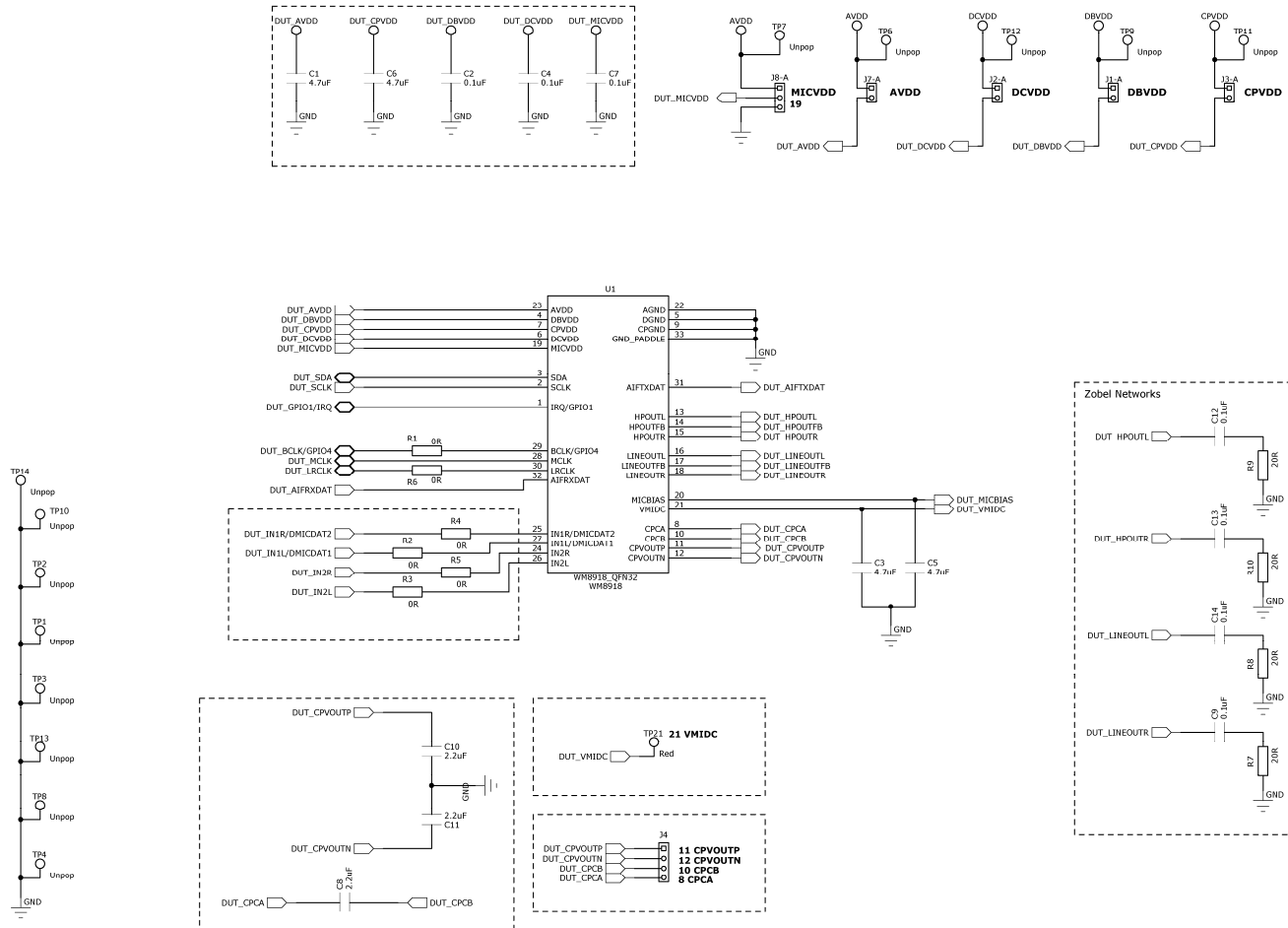

Sheet 2: MIC In and Headphone Out

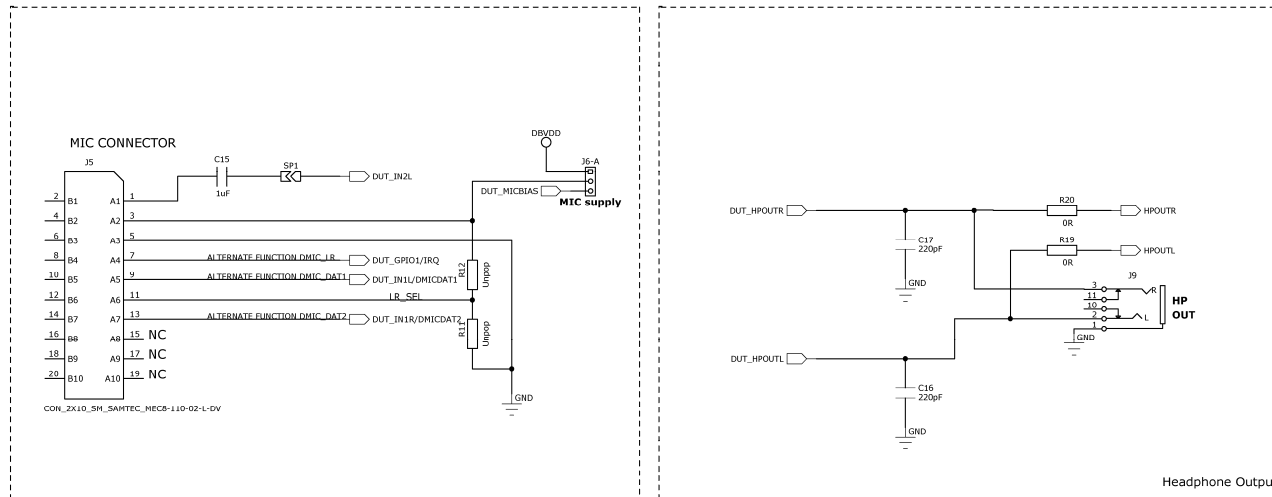

Sheet 3: Mini Board Headers

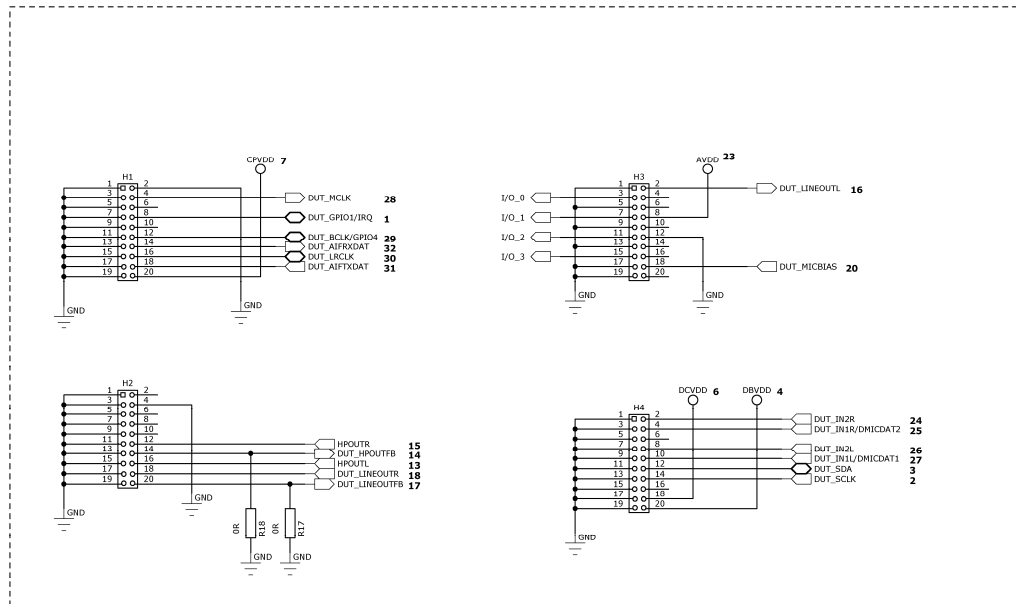
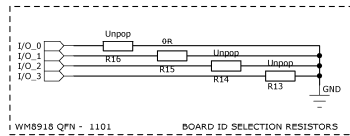

Sheet 4: Tables

REFERENCE TABLES

	Short	Open	LINK 31
31-B	DBVDD to DUT	No DBVDD to DUT	RED
PCB Ref:	DBVDD		Short
	Short	Open	LINK 32
32-B	DCVDD to DUT	No DCVDD to DUT	RED
PCB Ref:	DCVDD		Short
	Short	Open	LINK 37
37-B	AVDD to DUT	No AVDD to DUT	RED
PCB Ref:	AVDD		Short
	Short	Open	LINK 33
33-B	CPVDD to DUT	No CPVDD to DUT	RED
PCB Ref:	CPVDD		Short

	Short 1-2	Short 2-3	LINK 38
38-B	AVDD	external supply via header	RED
PCB Ref:	MICVDD		1-2
	Short 1-2	Short 2-3	LINK 36
36-B	DBVDD (DMIC)	MICBIAS (AMIC)	YELLOW
PCB Ref:	MIC supply		2-3

BILL OF MATERIALS (BOM)

<i>Item</i>	<i>RefDes</i>	<i>Description</i>	<i>Manufacturer</i>	<i>Manufacturer's Part Number</i>
1	J9	3.5mm Jack Socket 6.5mm Centre Height	Technik Industrial	TSH-3565-PBT-TIC-T
2	C10 C11	2.2uF 0603 SMD Ceramic Capacitor 10V X5R	MuRata	GRM188R61A225KE34D
3	C1 C3 C5 C6	4.7uF 0603 SMD Ceramic Capacitor 6.3V X5R	MuRata	GRM188R60J475KE19D
4	J1 J2 J3 J7	1x2 PCB Pin Header 0.1" VERTICAL	Harwin	M20-9990245
5	J6 J8	1x3 2.54mm Header Vertical	Harwin	M20-9990345
6	J4	1x4 2.54mm PCB Header Vertical	Harwin	M20-9990445
7	C8	2.2uF 0402 SMD Ceramic Capacitor 6.3V X5R	Kemet	C0402C225M9PAC
8	C15	1uF 0603 SMD Ceramic Capacitor 16V X7R	Phycomp	225524615663
9	MISC2	Lead-free label, 15mm round	Pro Power	7827260
10	C2 C4 C7	0.1uF 0603 SMD Ceramic Capacitor 16V X7R	Phycomp	2238 786 15649
11	C16 C17	220pF 0603 SMD Ceramic Capacitor 50V NPO	AVX	06035A221JAT2A
12	TP21	1.32mm PCB Test Terminal RED	Vero	20-313141
13	C9 C12 C13 C14	0.1uF 0402 SMD Ceramic Capacitor 16V X7R	MuRata	GRM155R71C104KA88D
14	R7 R8 R9 R10	20R 0603 SMD chip resistor 1% 0.063W	Multicomp	MC 0.063W 0603 1% 20R
15	R1 R2 R3 R4 R5 R6 R15 R17 R18 R19 R20	0R 0603 SMD chip resistor 1% 0.063W	Multicomp	MC 0.063W 0603 0R
16	LNK_J1 LNK_J2 LNK_J3 LNK_J7 LNK_J8	0.1" OPEN JUMPER LINK RED	Protech	22-3565
17	LNK_J6	0.1" OPEN JUMPER LINK YELLOW	Protech	22-3570
18	J5	2x10 way socket, mates with edge connector on 0.062" thick PCB	Samtec	MEC8-110-02-L-DV
19	H1 H2 H3 H4	2x10 2.54mm pitch PCB Socket Strip VERTICAL Long Lead	Samtec	SSQ-110-03-G-D
20	PCB1	PCB	Kelan Circuits Ltd	WM8918-6201-FL32-M-REV1
21	U1	WM8918 Ultra Low Power DAC for Portable Audio Applications	Wolfson Microelectronics	WM8918GEFL
Unpop				
22	R11 R12	10k 0603 SMD chip resistor 1% 0.063W	Multicomp	MC 0.063W 0603 1% 10K
23	R13 R14 R16	0R 0603 SMD chip resistor 1% 0.063W	Multicomp	MC 0.063W 0603 0R
24	SP1	Surface mount shorting point	N/A	N/A
25	TP1 TP2 TP3 TP4 TP6 TP7 TP8 TP9 TP10 TP11 TP12 TP13 TP14	1.32mm off-board connection point	N/A	N/A

PCB LAYOUT

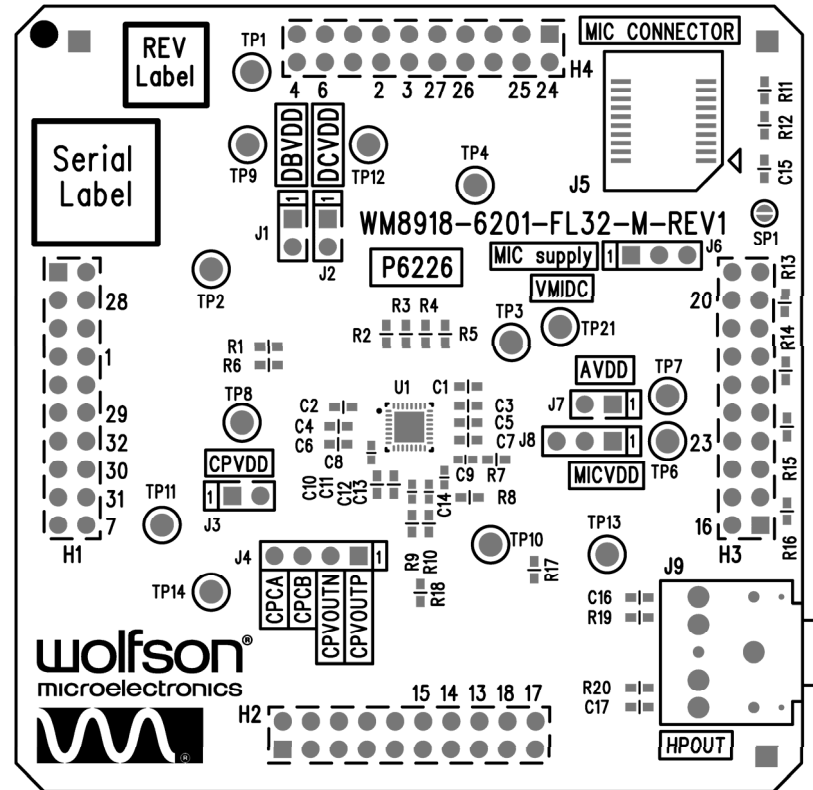

Top Layer: Overview

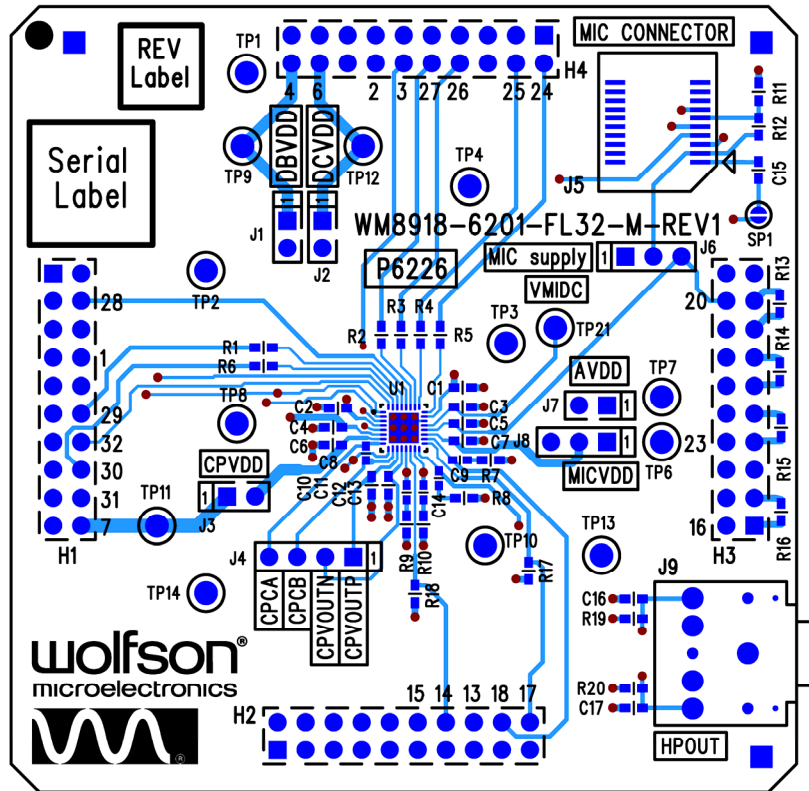

Top Layer: Silkscreen + Copper

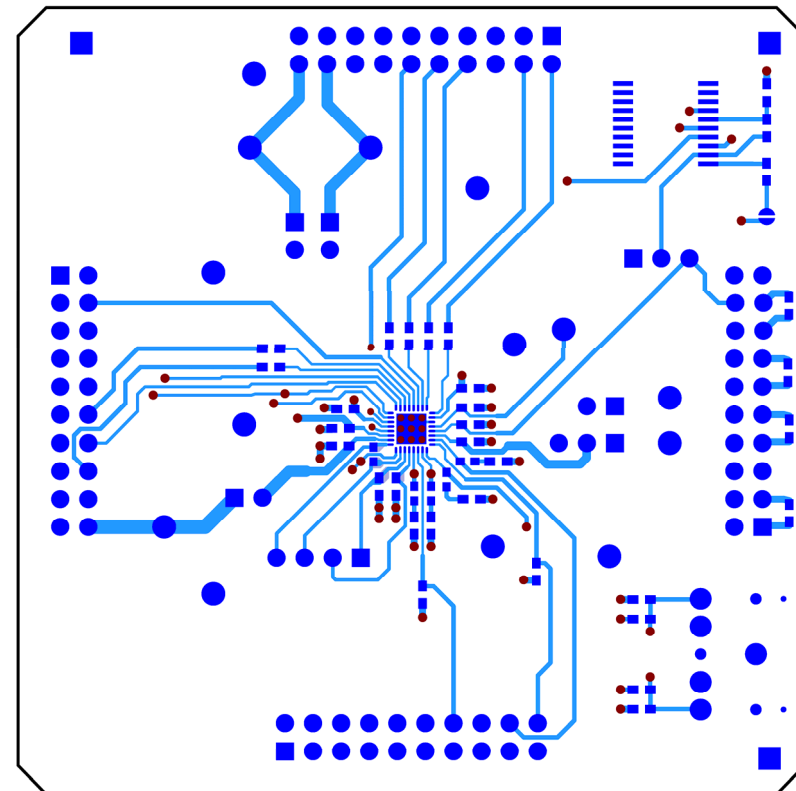

Top Layer: Copper

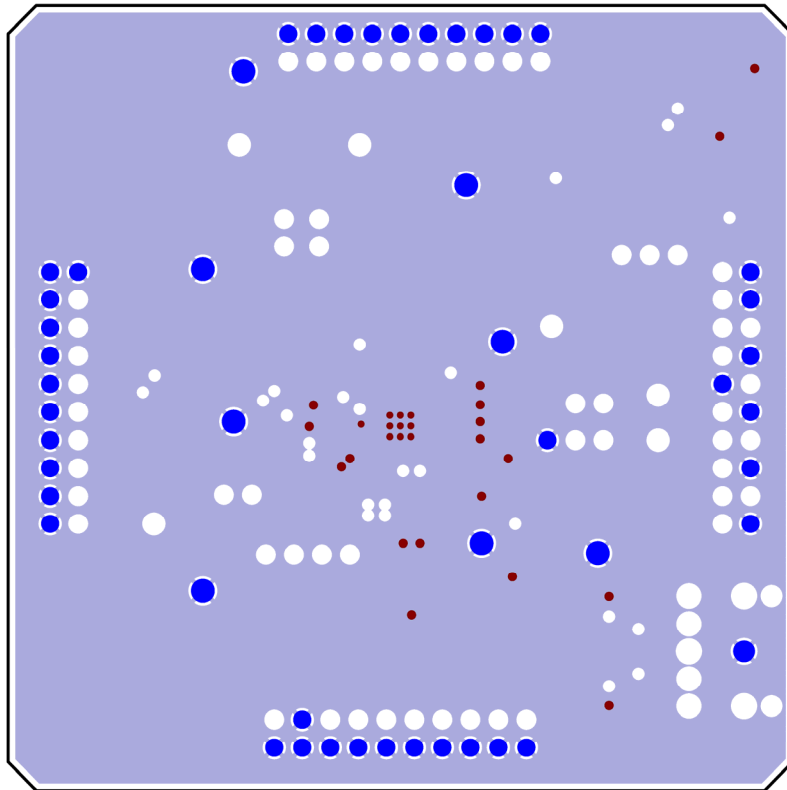

Layer 2: Copper

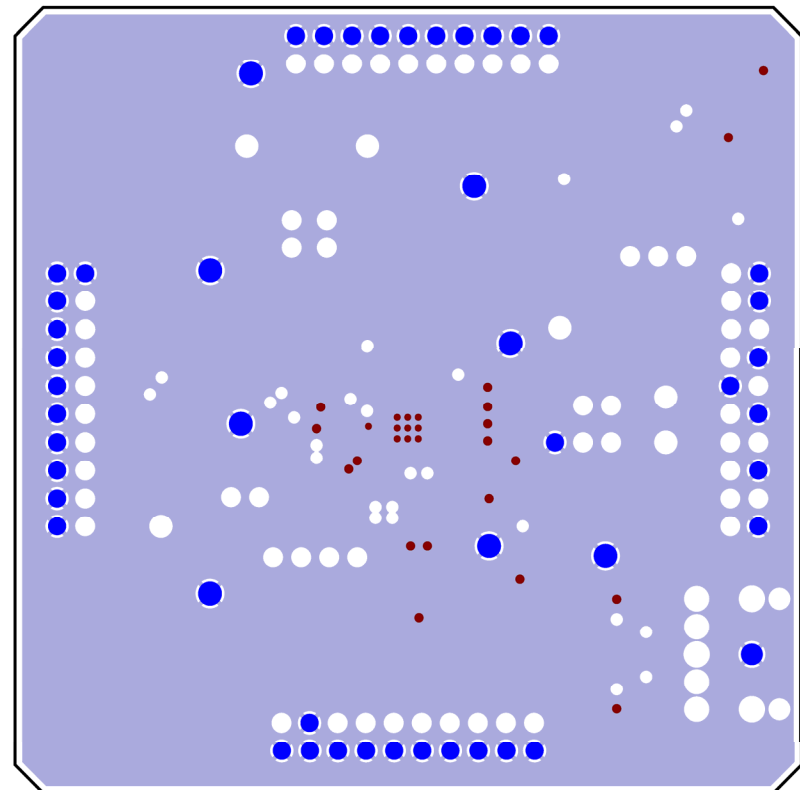

Layer 3: Copper

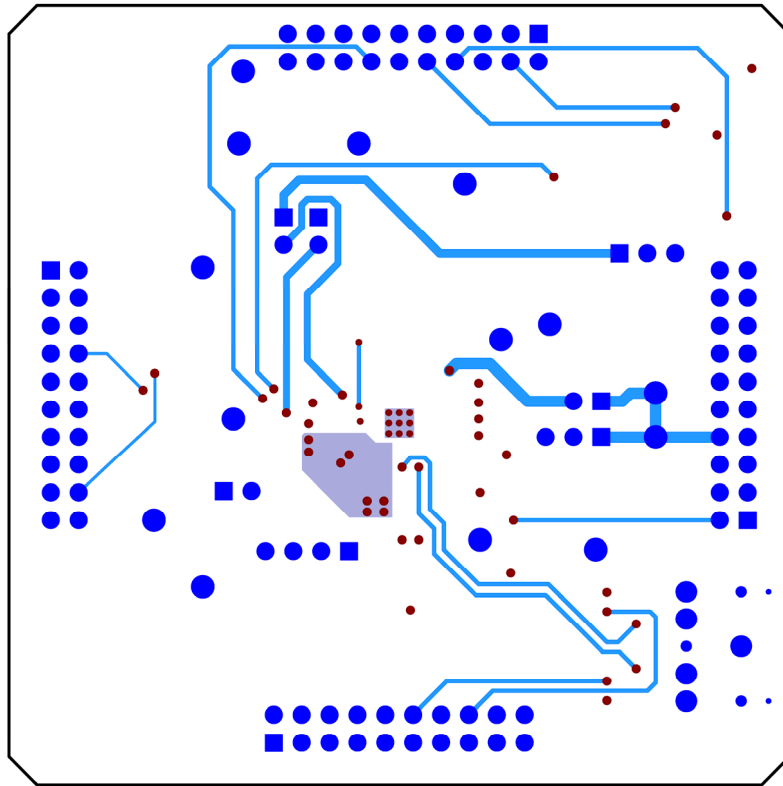

Bottom Layer: Copper

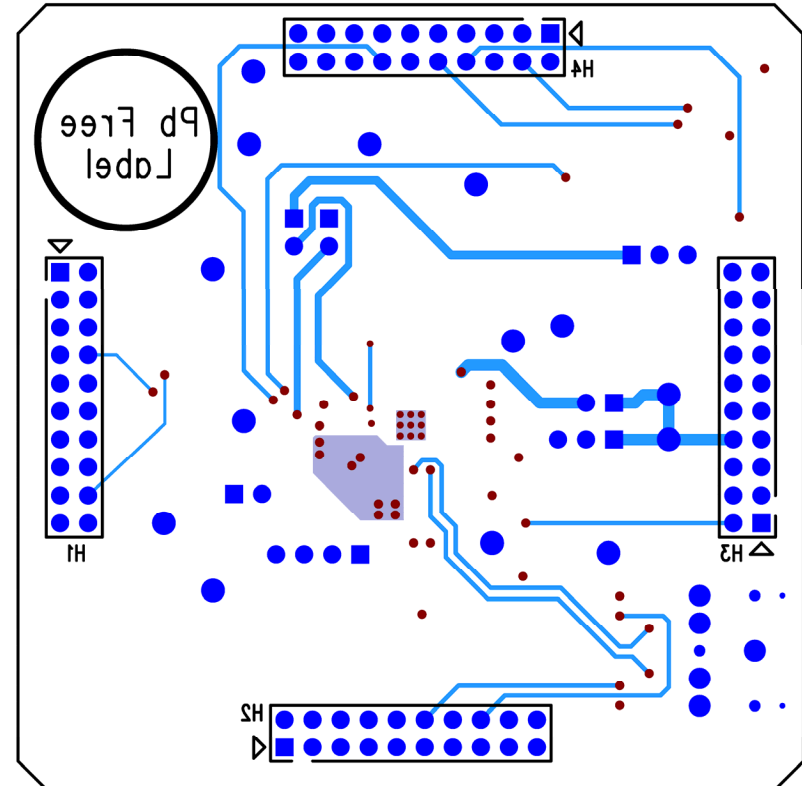

Bottom Layer: Silkscreen + Copper

APPLICATION SUPPORT

If you require more information or require technical support, please contact the Wolfson Microelectronics Applications group through the following channels:

Email: apps@wolfsonmicro.com
Telephone Apps: +44 (0) 131 272 7070
Fax: +44 (0) 131 272 7001
Mail: Applications Engineering at the address on the last page

or contact your local Wolfson representative.

Additional information may be made available on our web site at: <http://www.wolfsonmicro.com>

IMPORTANT NOTICE

Wolfson Microelectronics plc (“Wolfson”) products and services are sold subject to Wolfson’s terms and conditions of sale, delivery and payment supplied at the time of order acknowledgement.

Wolfson warrants performance of its products to the specifications in effect at the date of shipment. Wolfson reserves the right to make changes to its products and specifications or to discontinue any product or service without notice. Customers should therefore obtain the latest version of relevant information from Wolfson to verify that the information is current.

Testing and other quality control techniques are utilised to the extent Wolfson deems necessary to support its warranty. Specific testing of all parameters of each device is not necessarily performed unless required by law or regulation.

In order to minimise risks associated with customer applications, the customer must use adequate design and operating safeguards to minimise inherent or procedural hazards. Wolfson is not liable for applications assistance or customer product design. The customer is solely responsible for its selection and use of Wolfson products. Wolfson is not liable for such selection or use nor for use of any circuitry other than circuitry entirely embodied in a Wolfson product.

Wolfson’s products are not intended for use in life support systems, appliances, nuclear systems or systems where malfunction can reasonably be expected to result in personal injury, death or severe property or environmental damage. Any use of products by the customer for such purposes is at the customer’s own risk.

Wolfson does not grant any licence (express or implied) under any patent right, copyright, mask work right or other intellectual property right of Wolfson covering or relating to any combination, machine, or process in which its products or services might be or are used. Any provision or publication of any third party’s products or services does not constitute Wolfson’s approval, licence, warranty or endorsement thereof. Any third party trade marks contained in this document belong to the respective third party owner.

Reproduction of information from Wolfson datasheets is permissible only if reproduction is without alteration and is accompanied by all associated copyright, proprietary and other notices (including this notice) and conditions. Wolfson is not liable for any unauthorised alteration of such information or for any reliance placed thereon.

Any representations made, warranties given, and/or liabilities accepted by any person which differ from those contained in this datasheet or in Wolfson’s standard terms and conditions of sale, delivery and payment are made, given and/or accepted at that person’s own risk. Wolfson is not liable for any such representations, warranties or liabilities or for any reliance placed thereon by any person.

ADDRESS:

Wolfson Microelectronics plc
Westfield House
26 Westfield Road
Edinburgh
EH11 2QB
United Kingdom
Tel :: +44 (0)131 272 7000
Fax :: +44 (0)131 272 7001
Email :: apps@wolfsonmicro.com