

DOC TYPE:	Schematic and Layout
BOARD REFERENCE:	WM8950-6140-FL24-EV1-REV3
BOARD TYPE:	Customer Main
WOLFSON DEVICE(S):	WM8950
DATE:	March 2008
DOC REVISION:	Rev 1.1

Schematic

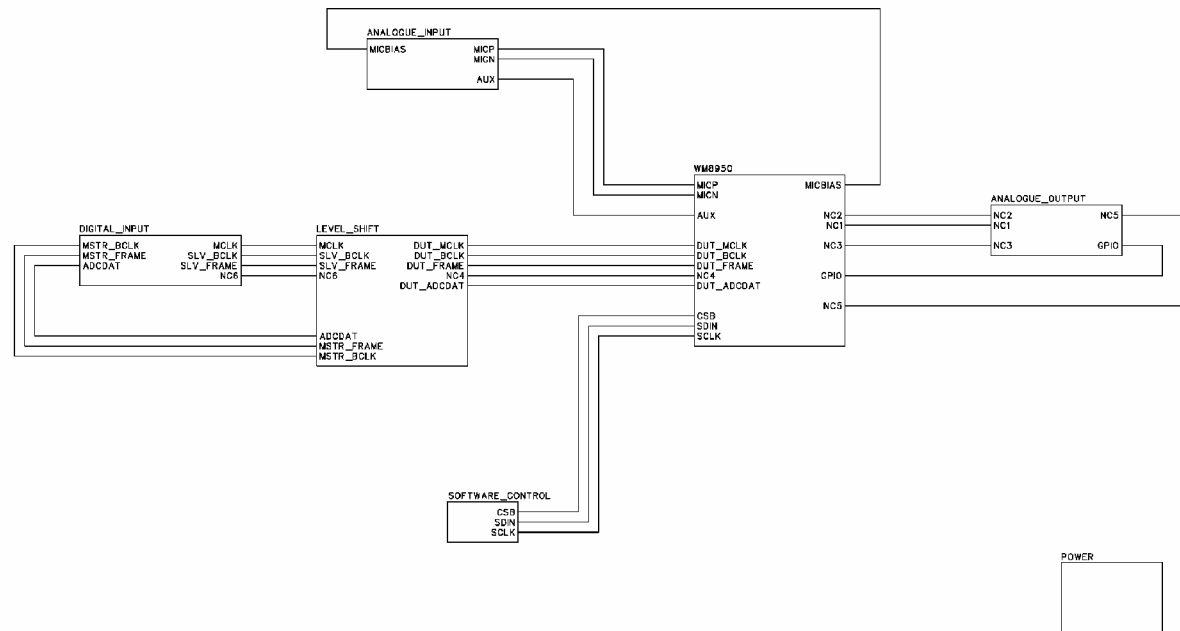

Sheet 1: Functional Diagram

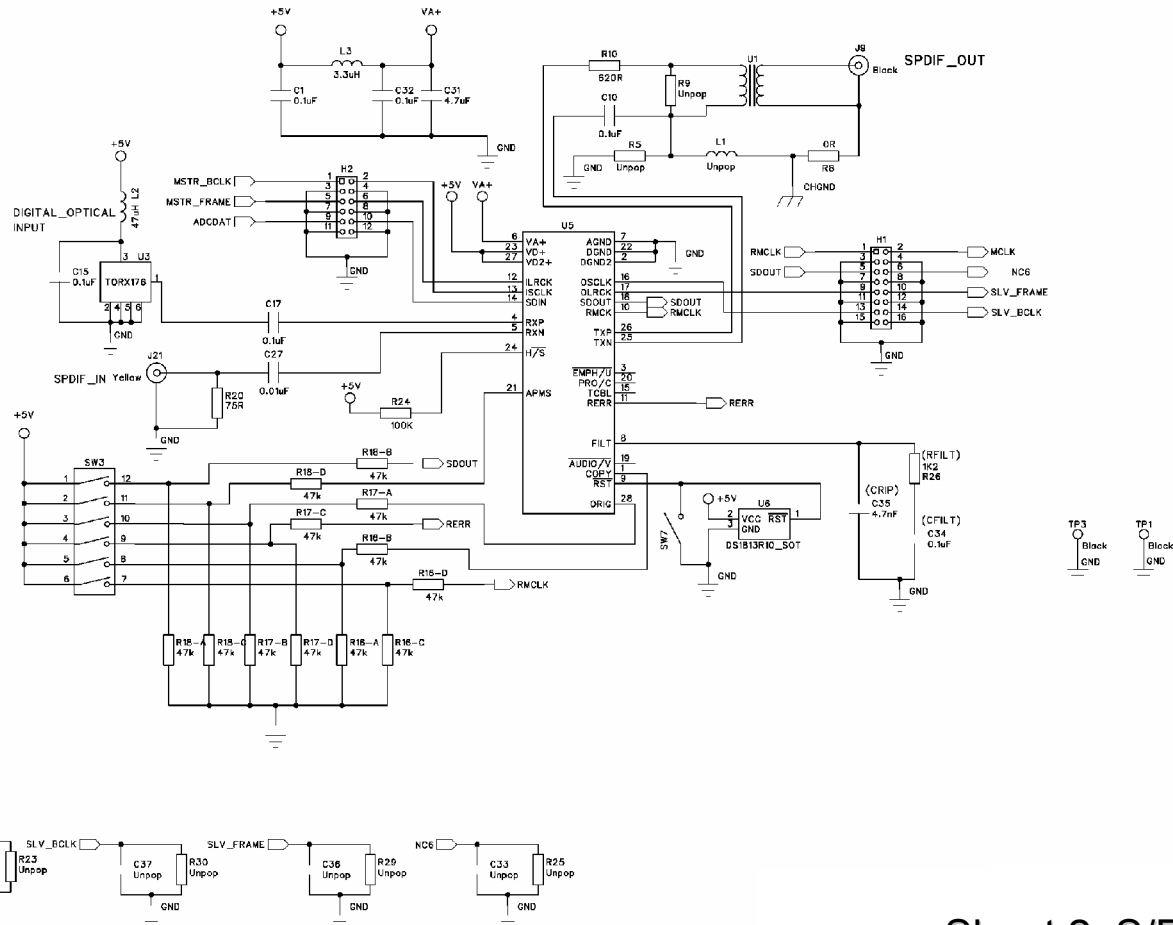

Sheet 2: S/PDIF Interface

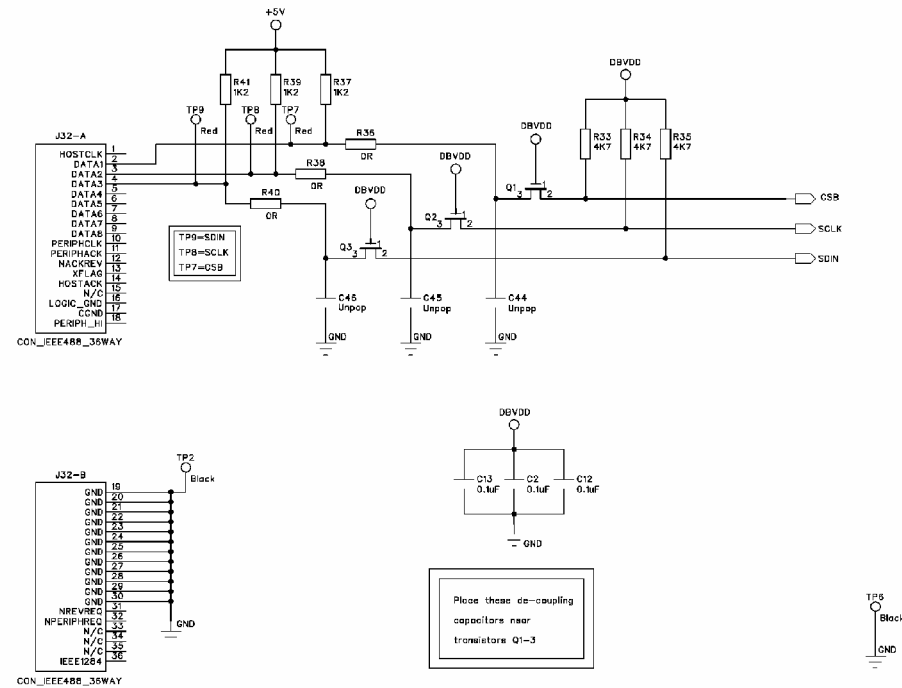

De-coupling for Level Shift U5

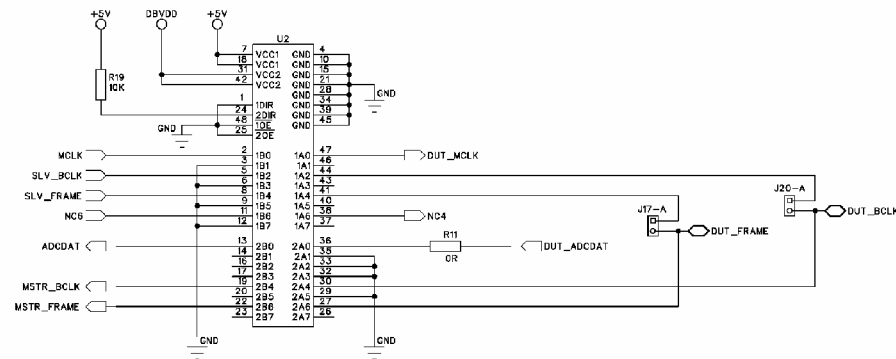
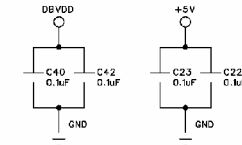

J17 & J20:
Pin1 = SLAVE Input
Pin2 = MASTER Output
Short both when using SLAVE mode.

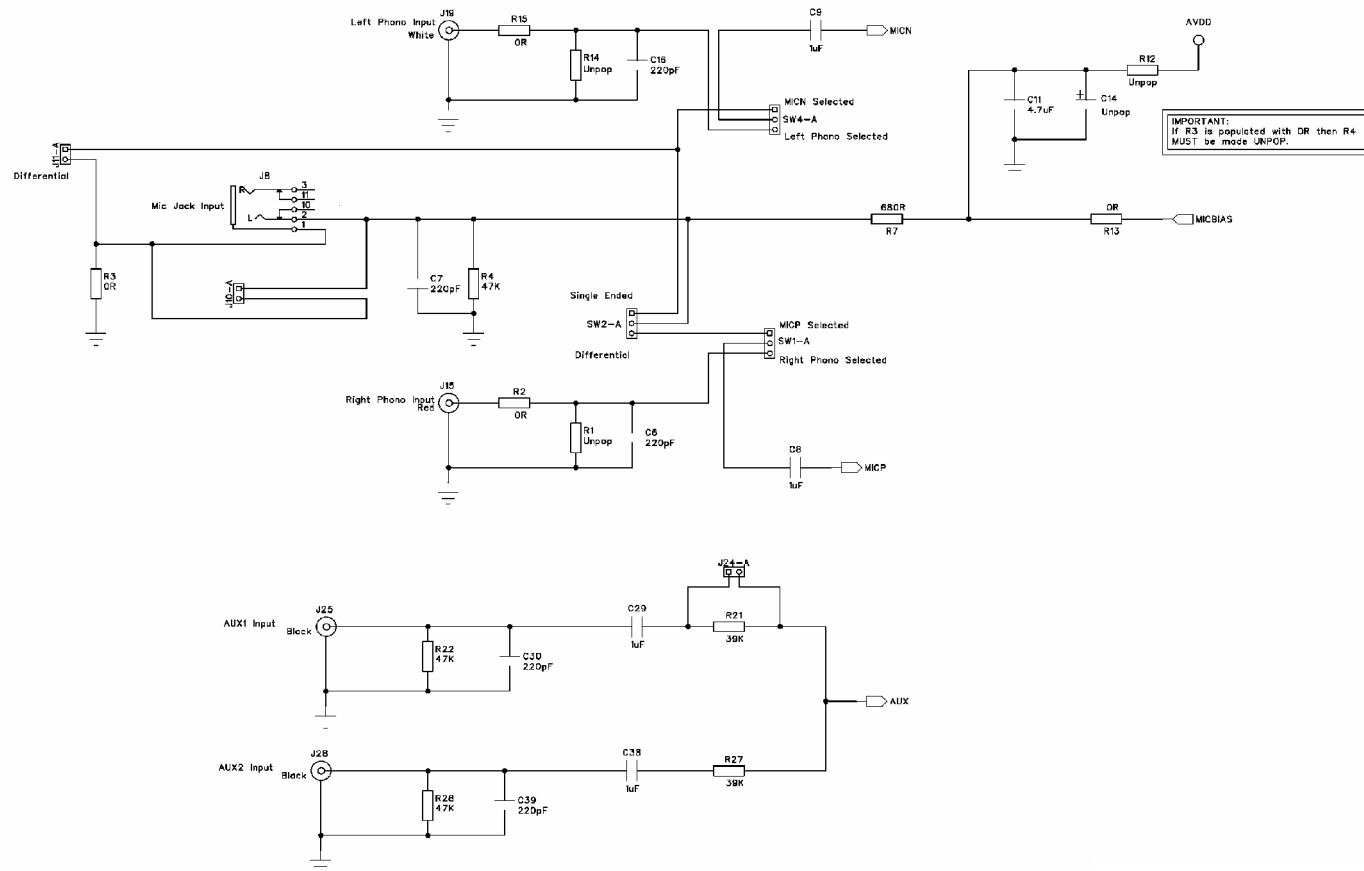

Sheet 5: Analogue Input

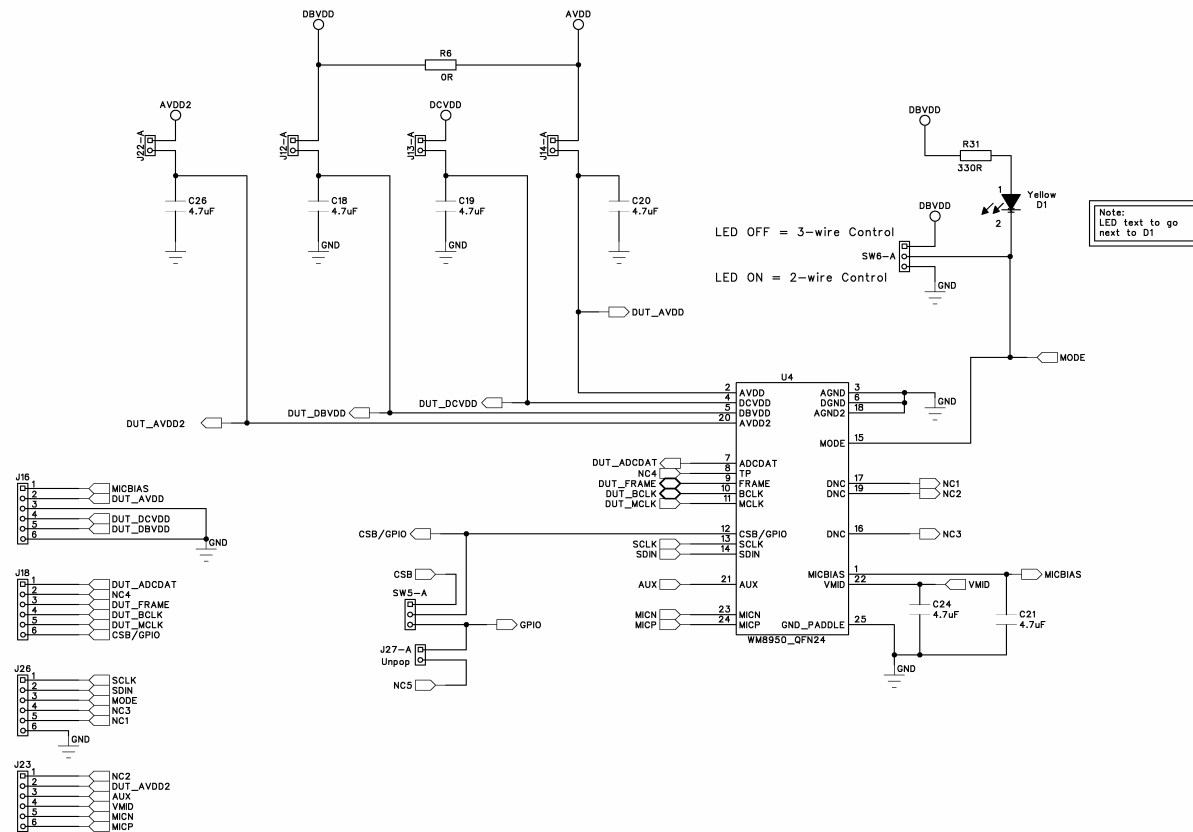

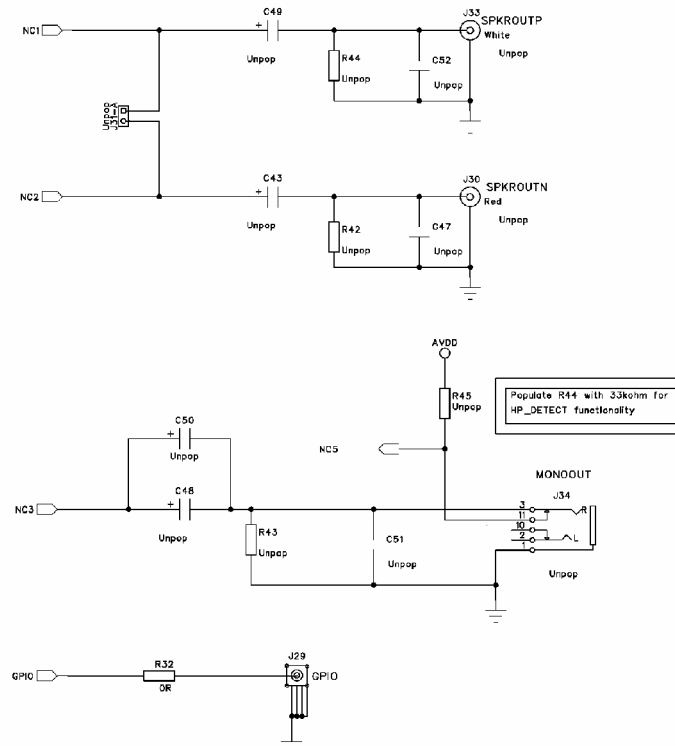

Sheet 7: Analogue Output

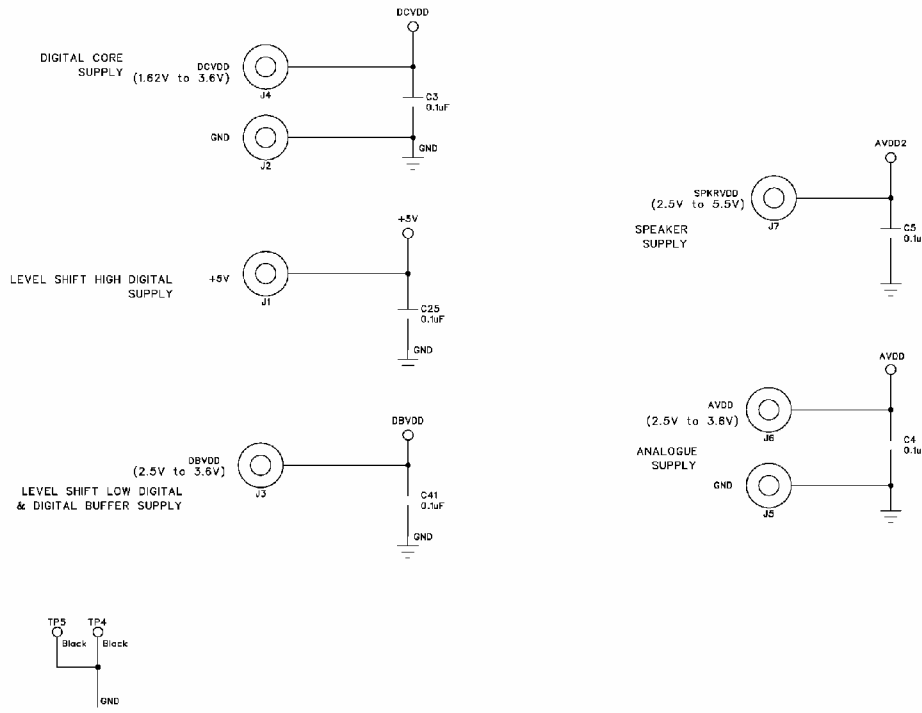

NOTE :

1. All GND's must be within 0.3V of each other.
2. All Analogue & Digital supplies are independent of each other
3. DCVDD must be less than or equal to AVDD & DBVDD

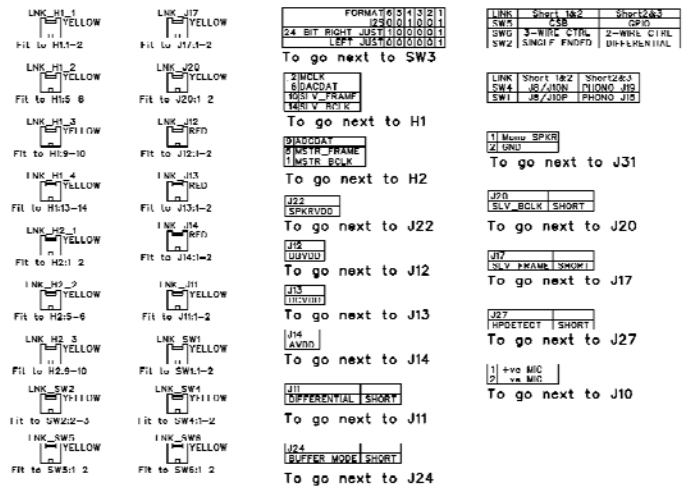

Bill Of Materials (BOM)

<i>Item</i>	<i>RefDes</i>	<i>Description</i>	<i>Manufacturer</i>	<i>Manufacturer's Part Number</i>	<i>Qty</i>
1	J8	3.5mm Jack Socket 6.5mm Centre Height	Technik Industrial	TSH3565	1
2	U2	74ALVC164245 16 Bit Dual Supply Bus Transceiver SSO	Philips	74ALVC164245DL	1
3	L3	3.3uH 1210 Surface Mount Inductor '1210A series'	Epcos	B82422A1332K100	1
4	J9 J25 J28	Phono Socket PCB mount BLACK	Dragon City	RS109 - Black	3
5	J21	Phono Socket PCB mount YELLOW	Dragon City	RS109 - Yellow	2
6	J15	Phono Socket PCB mount RED	Dragon City	RS-109 Red	2
7	J19	Phono Socket PCB mount WHITE	Dragon City	RS-109 White	2
8	H2	2x6 2.54mm pitch PCB Pin Header VERTICAL	Harwin	M20-9980645	2
9	H1	2x8 2.54mm pitch PCB Pin Header VERTICAL	Harwin	M20-9980845	2
10	J10 J11 J12 J13 J14 J17 J20 J22 J24	1x2 PCB Pin Header 0.1" VERTICAL	Harwin	M20-9990245	9
11	SW1 SW2 SW4 SW5 SW6	1x3 2.54mm Header Vertical	Harwin	M20-9990345	5
12	J16 J18 J23 J26	1x6 2.54mm Header Vertical	Harwin	M20-9990645	4
13	Q1 Q2 Q3	TN0200T N- Channel MOSFET SOT23	Vishay	TN0200K-T1-E3	3
14	J29	SMB Connector PCB Mount 50 Ohm VERTICAL	Amphenol	SMB1251B1-3GT30G-50	1
15	J32	36-way Centronics/IEE488 PCB mountable Connector	Multicomp	147-753	1

<i>Item</i>	<i>RefDes</i>	<i>Description</i>	<i>Manufacturer</i>	<i>Manufacturer's Part Number</i>	<i>Qty</i>
16	L2	47uH 1210 Surface Mount Inductor 'PA series'	Panasonic	ELJPA470KF	1
17	SW7	B3F1000 SPNO PCB mount switch	Omron	B3F-1000	1
18	C6 C7 C16 C30 C39	220pF 0805 SMD Ceramic Capacitor 50V X7R	Phycomp	2238 580 15614	5
19	C27	0.01uF 0805 SMD Ceramic Capacitor 50V X7R	Phycomp	08052R103K9B2	1
20	C1 C2 C3 C4 C5 C10 C12 C13 C15 C17 C22 C23 C25 C40 C41 C42	0.1uF 0805 SMD Ceramic Capacitor 50V X7R	Phycomp	08052R104K9B2	16
21	C35	4.7nF 0603 SMD Ceramic Capacitor 50V X7R	AVX	06035C472KAT2A	1
22	C32 C34	0.1uF 0603 SMD Ceramic Capacitor 16V X7R	Phycomp	06032R104K7B2	2
23	P1 P2 P3 P4	Hexagonal brass M3 size spacer 20mm length	Harwin	R6379-02	4
24	TP1 TP2 TP3 TP4 TP5 TP6	1.32mm PCB Test Terminal BLACK	VERO	20-2136	6
25	TP7 TP8 TP9	1.32mm PCB Test Terminal RED	Vero	20-313141	3
26	SC1 SC2 SC3 SC4	Slotted Panhead Screw - M3 thread; 12mm long	Roebuck	PFP527	4
27	W1 W2 W3 W4	Plain M3 size washer	Roebuck	PFP2497	4
28	C11 C18 C19 C20 C21 C24 C26 C31	4.7uF 0805 SMD Ceramic Capacitor 16V X5R	Kemet	C0805C475K4PAC	8
29	R16 R17 R18	47k 1206 SMD chip 4 resistor array 5% 0.063W	Phycomp	2350 035 10473	3
30	R26	1K2 0603 SMD chip resistor 1% 0.063W	Multicomp	MC 0.063W 0603 1%1K2	1

<i>Item</i>	<i>RefDes</i>	<i>Description</i>	<i>Manufacturer</i>	<i>Manufacturer's Part Number</i>	<i>Qty</i>
31	R2 R3 R15 R32	0R 0603 SMD chip resistor 1% 0.063W	Multicomp	MC 0.063W 0603 0R	4
32	R19	10K 0805 SMD chip resistor 1% 0.1W	Multicomp	MC 0.1W 0805 1% 10K	1
33	R24	100K 0805 SMD chip resistor 1% 0.1W	Multicomp	MC 0.1W 0805 1% 100K	1
34	R37 R39 R41	1K2 0805 SMD chip resistor 1% 0.1W	Multicomp	MC 0.1W 0805 1% 1K2	3
35	R31	330R 0805 SMD chip resistor 1% 0.1W	Multicomp	MC 0.1W 0805 1% 330R	1
36	R21 R27	39K 0805 SMD chip resistor 1% 0.1W	Multicomp	MC 0.1W 0805 1% 39K	2
37	R33 R34 R35	4K7 0805 SMD chip resistor 1% 0.1W	Multicomp	MC 0.1W 0805 1% 4K7	3
38	R4 R22 R28	47K 0805 SMD chip resistor 1% 0.1W	Multicomp	MC 0.1W 0805 1% 47K	3
39	R10	620R 0805 SMD chip resistor 1% 0.1W	Multicomp	MC 0.1W 0805 1% 620R	1
40	R7	680R 0805 SMD chip resistor 1% 0.1W	Multicomp	MC 0.1W 0805 1% 680R	1
41	R8 R11 R13 R36 R38 R40	0R 0805 SMD chip resistor 1% 0.1W	Multicomp	MC 0.1W 0805 0R	6
42	R6	0R 1206 SMD chip resistor	Multicomp	MC 0.125W 1206 0R	1
43	C8 C9 C29 C38	1uF 0805 SMD Ceramic Capacitor 10V X7R	Multicomp	N0805R105KCT	4
44	SW3	DIL Switch 6-Way Rocker	Grayhill	76SB06T	1
45	U6	DS1813 5V active Low Power-On-Reset chip SOT	Dallas Semiconductor	DS1813R-10+	1
46	J1 J2 J3 J4 J5 J6 J7	4mm Non-Insulated Panel Socket 16A	PJP	3110I	7

<i>Item</i>	<i>RefDes</i>	<i>Description</i>	<i>Manufacturer</i>	<i>Manufacturer's Part Number</i>	<i>Qty</i>
47	LNK_J12 LNK_J13 LNK_J14	0.1" OPEN JUMPER LINK RED	Protech	22-3565	3
48	LNK_H1_1 LNK_H1_2 LNK_H1_3 LNK_H1_4 LNK_H2_1 LNK_H2_2 LNK_H2_3 LNK_J11 LNK_J17 LNK_J20 LNK_SW1 LNK_SW2 LNK_SW4 LNK_SW5 LNK_SW6	0.1" OPEN JUMPER LINK YELLOW	Protech	22-3570	15
49	R20	75R 0805 SMD chip resistor 1% 0.125W	Neohm	CRG08051%75R0	1
50	D1	KP-2012SYC 0805 SMD Chip LED YELLOW	Kingbright	KP-2012SYC	1
51	U1	2:1 Ratio 96KHz SPDIF Digital Audio transformer SOIC	Scientific Conversion	SC982-04LF	1
52	U3	TORX176 Digirtal Audio Optical Receiver	Toshiba	TORX176(F)	1
53	U5	CS8427 96KHz Audio Transceiver	Crystal Semiconductor	CS8427-CSZ	1
72	U4	WM8950 ADC with Mic In QFN	Wolfson Microelectronics	WM8950GEFL/V	1

<i>Item</i>	<i>RefDes</i>	<i>Description</i>	<i>Manufacturer</i>	<i>Manufacturer's Part Number</i>	<i>Qty</i>
Unpop					
54	J34	3.5mm Jack Socket 6.5mm Centre Height	Technik Industrial	TSH3565	1
55	J30	Phono Socket PCB mount RED	Dragon City	RS-109 Red	1
56	J33	Phono Socket PCB mount WHITE	Dragon City	RS-109 White	1
57	R45	33k 0603 SMD chip resistor 1% 0.063W	Multicomp	MC 0.063W 0603 1% 33K	1
58	J27 J31	1x2 PCB Pin Header 0.1" VERTICAL	Harwin	M20-9990245	2
59	C48	100uF CASE T Surface Mount 6.3V	AVX	TACT107M006XTA	1
60	C47 C51 C52	220pF 0805 SMD Ceramic Capacitor 50V X7R	Phycomp	2238 580 15614	3
61	C44 C45 C46	0.1uF 0805 SMD Ceramic Capacitor 50V X7R	Phycomp	08052R104K9B2	3
62	C28 C33 C36 C37	22pF 0805 SMD Ceramic Capacitor 100V NPO	AVX	08051A220JAT2A	4
63	R1 R14	5k6 0603 SMD chip resistor 1% 0.063W	Multicomp	MC 0.063W 0603 1% 5K6	2
64	R9	100R 0805 SMD chip resistor 1% 0.1W	Multicomp	MC 0.1W 0805 1% 100R	1
65	R42 R44	10K 0805 SMD chip resistor 1% 0.1W	Multicomp	MC 0.1W 0805 1% 10K	2
66	R43	47K 0805 SMD chip resistor 1% 0.1W	Multicomp	MC 0.1W 0805 1% 47K	1
67	R5 R12	0R 0805 SMD chip resistor 1% 0.1W	Multicomp	MC 0.1W 0805 0R	2
68	L1	0R 1206 Resistor on 1210 Inductor site	Multicomp	MC 0.125W 1206 0R	1
69	R23 R25 R29 R30	49R9 0805 SMD chip resistor 1% 0.125W	Rohm	MCR10EZHEF49R9	4



WM8950-6140-FL24-EV1-REV3

Schematic and Layout

<i>Item</i>	<i>RefDes</i>	<i>Description</i>	<i>Manufacturer</i>	<i>Manufacturer's Part Number</i>	<i>Qty</i>
Unpop					
70	C14 C43 C49	10uF 6.3 Dia 2.5 pitch Oscon Through Hole Cap. 25V 20%	Sanyo	25SC10M	3
71	C50	220uF 10 Dia 5 pitch Low Impedance TH Cap. 35V 20%	Panasonic	EEUFC1V221	1

Layout

Top Silkscreen

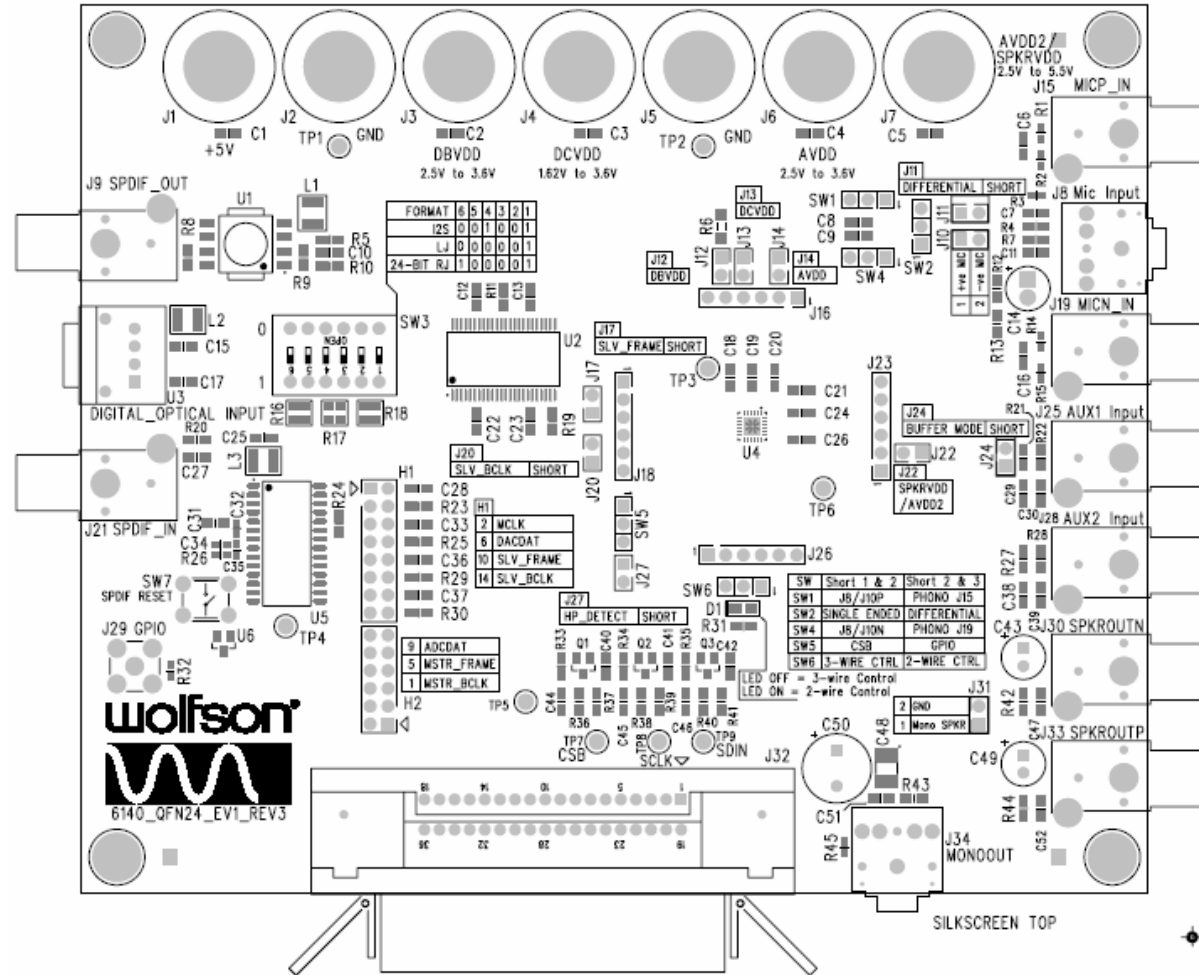

Generic Board Configuration

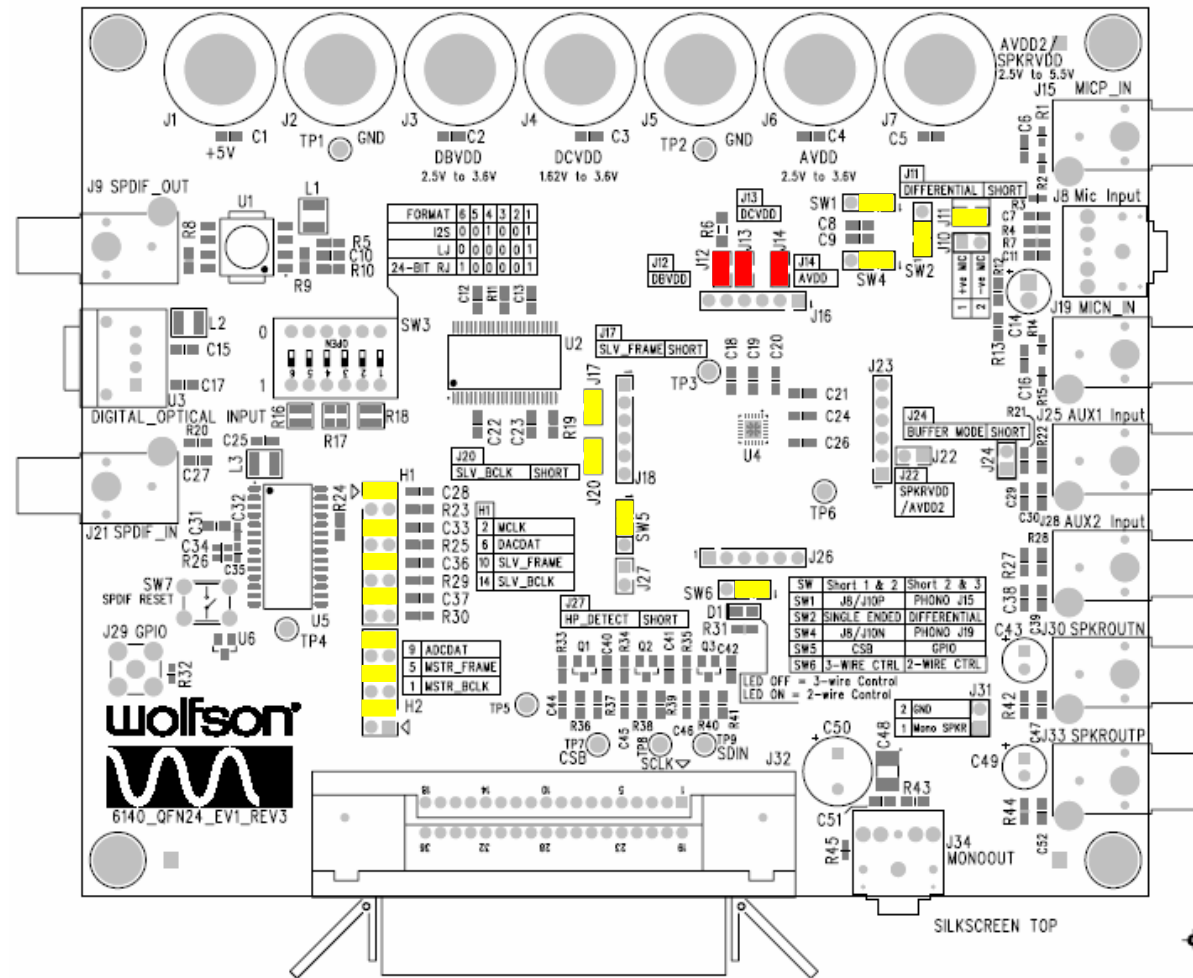

Application Support

If you require more information or require technical support, please contact the Wolfson Microelectronics Applications group through the following channels:

Email: apps@wolfsonmicro.com
Telephone Apps: +44 (0) 131 272 7070
Fax: +44 (0) 131 272 7001
Mail: Applications Engineering at the address on the last page

or contact your local Wolfson representative.

Additional information may be made available on our web site at: <http://www.wolfsonmicro.com>

Important Notice

Wolfson Microelectronics plc ("Wolfson") products and services are sold subject to Wolfson's terms and conditions of sale, delivery and payment supplied at the time of order acknowledgement.

Wolfson warrants performance of its products to the specifications in effect at the date of shipment. Wolfson reserves the right to make changes to its products and specifications or to discontinue any product or service without notice. Customers should therefore obtain the latest version of relevant information from Wolfson to verify that the information is current.

Testing and other quality control techniques are utilised to the extent Wolfson deems necessary to support its warranty. Specific testing of all parameters of each device is not necessarily performed unless required by law or regulation.

In order to minimise risks associated with customer applications, the customer must use adequate design and operating safeguards to minimise inherent or procedural hazards. Wolfson is not liable for applications assistance or customer product design. The customer is solely responsible for its selection and use of Wolfson products. Wolfson is not liable for such selection or use nor for use of any circuitry other than circuitry entirely embodied in a Wolfson product.

Wolfson's products are not intended for use in life support systems, appliances, nuclear systems or systems where malfunction can reasonably be expected to result in personal injury, death or severe property or environmental damage. Any use of products by the customer for such purposes is at the customer's own risk.

Wolfson does not grant any licence (express or implied) under any patent right, copyright, mask work right or other intellectual property right of Wolfson covering or relating to any combination, machine, or process in which its products or services might be or are used. Any provision or publication of any third party's products or services does not constitute Wolfson's approval, licence, warranty or endorsement thereof. Any third party trade marks contained in this document belong to the respective third party owner.

Reproduction of information from Wolfson datasheets is permissible only if reproduction is without alteration and is accompanied by all associated copyright, proprietary and other notices (including this notice) and conditions. Wolfson is not liable for any unauthorised alteration of such information or for any reliance placed thereon.

Any representations made, warranties given, and/or liabilities accepted by any person which differ from those contained in this datasheet or in Wolfson's standard terms and conditions of sale, delivery and payment are made, given and/or accepted at that person's own risk. Wolfson is not liable for any such representations, warranties or liabilities or for any reliance placed thereon by any person.

ADDRESS:

Wolfson Microelectronics plc
Westfield House
26 Westfield Road
Edinburgh
EH11 2QB
United Kingdom
Tel :: +44 (0)131 272 7000
Fax :: +44 (0)131 272 7001
Email :: apps@wolfsonmicro.com

Revision History

REVISION	DATE	ORIGINATOR	CHANGE
1.0	14/02/2008	BC	Initial release
1.1	20/3/08	BC	Headings changed