

DOC TYPE:	SCHEMATIC AND LAYOUT
BOARD REFERENCE:	WM7121-1701-MS4-M-REV1
BOARD TYPE:	Customer Mini
WOLFSON DEVICE(S):	WM7121
DATE:	January 2013
DOC REVISION:	Rev 1.0

SCHEMATIC

Sheet 1: WM7121

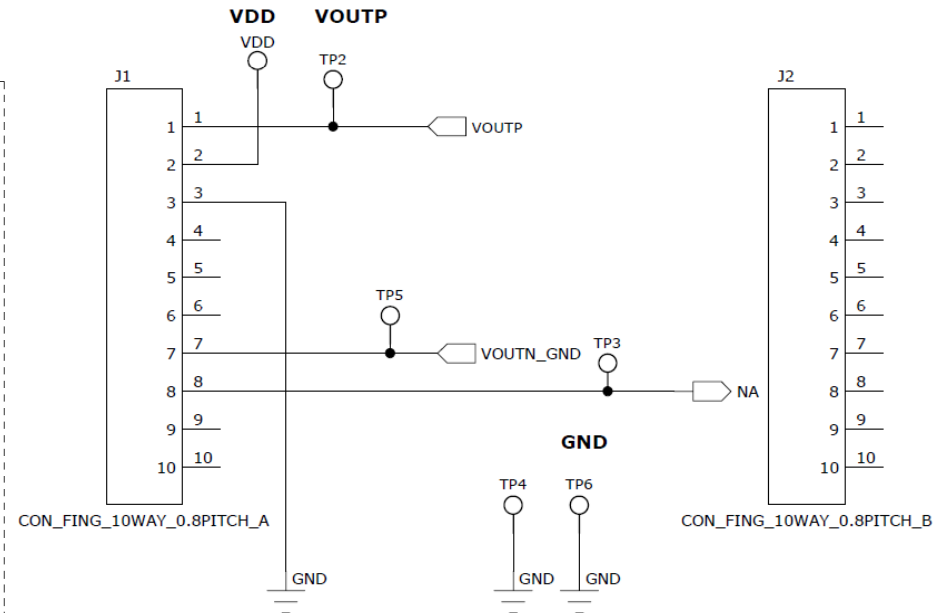
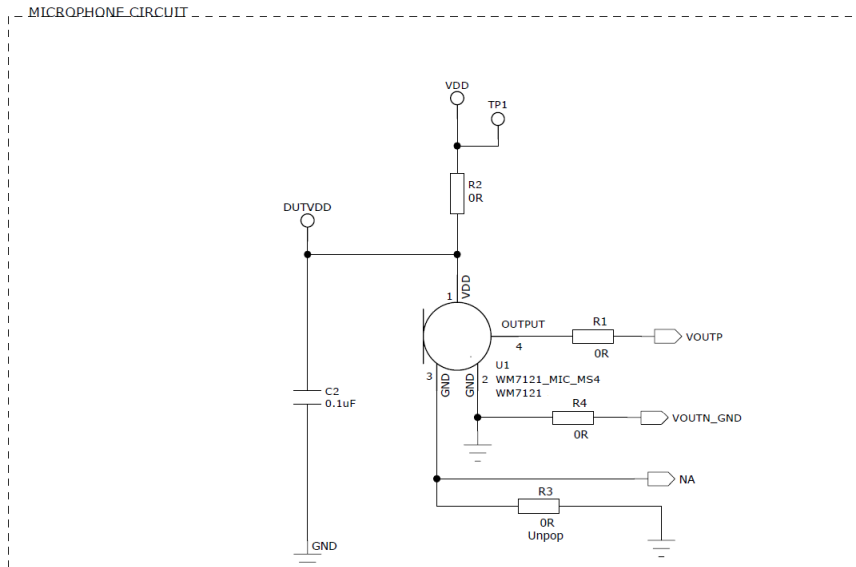

BILL OF MATERIALS(BOM)

<i>Item</i>	<i>RefDes</i>	<i>Description</i>	<i>Manufacturer</i>	<i>Manufacturer's Part Number</i>
1	C2	0.1uF 0603 SMD Ceramic Capacitor 16V X7R	Phycomp	2238 786 15649
2	R1	0R 0603 SMD chip resistor 1% 0.063W	Multicomp	MC 0.063W 0603 0R
3	R4	0R 0603 SMD chip resistor 1% 0.063W	Multicomp	MC 0.063W 0603 0R
4	R2	0R 0805 SMD chip resistor 1% 0.1W	Multicomp	MC 0.1W 0805 0R
5	U1	WM7121 Top Port Analogue Silicon Microphone	Wolfson Microelectronics	WM7121
6	PCB1	PCB	ZOT Engineering	WM7121-1701-MS4-M-REV1
Unpop				
7	J1	1x10 0.8mm Top Side Edge Finger Connector		
8	J2	1x10 0.8mm Bottom Side Edge Finger Connector		
9	TP1, TP2, TP3, TP4,TP5,TP6	1.0mm PCB Hole test point		
10	R3	0R 0603 SMD chip resistor 1% 0.063W	Multicomp	MC 0.063W 0603 0R

PCB LAYOUT



Top Layer: Overview

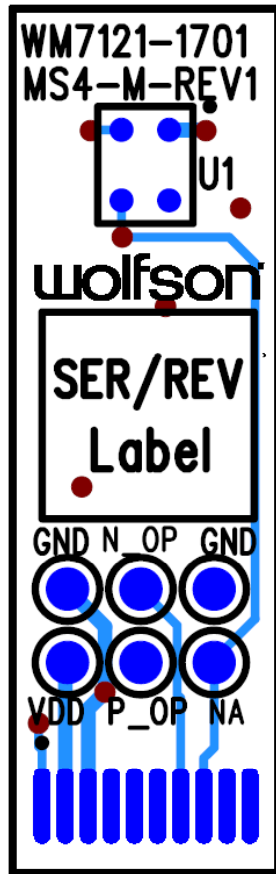

Top Layer: Silkscreen + Copper

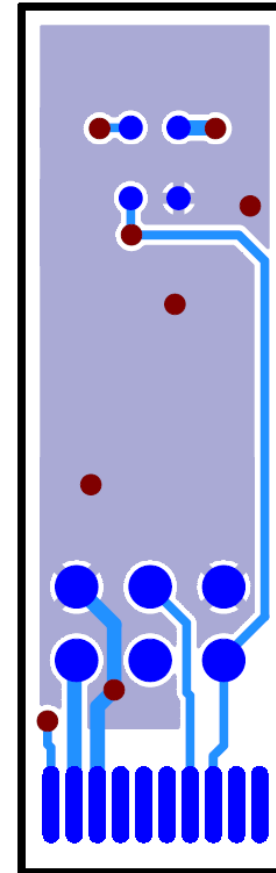

Top Layer: Copper

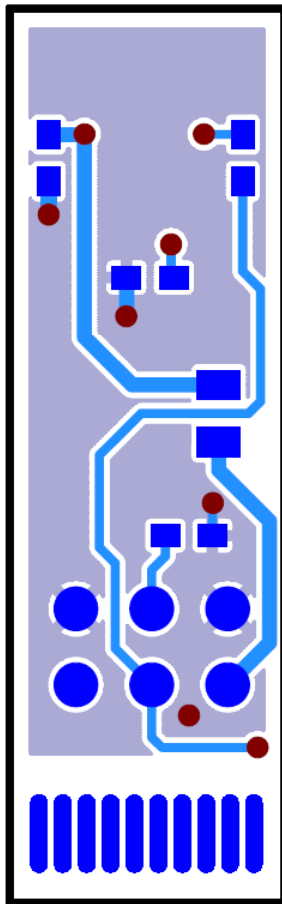

Layer 2: Copper

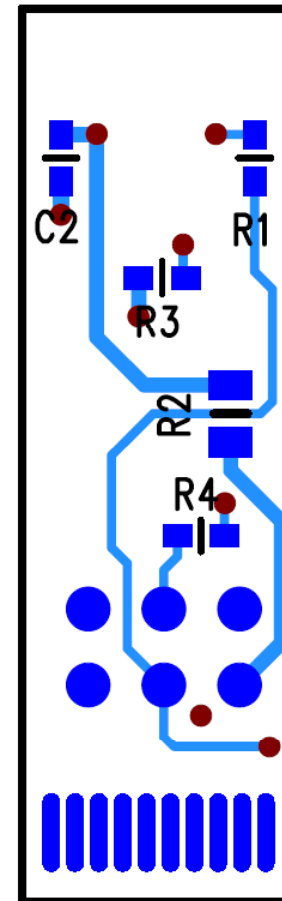

Layer 3: Copper



WM7121-1701-MS4-M-REV1

Schematic and Layout

TECHNICAL SUPPORT

If you require more information or require technical support, please contact the nearest Wolfson Microelectronics regional office:

<http://www.wolfsonmicro.com/contact>

or one of our global distributors:

<http://www.wolfsonmicro.com/distribution>

IMPORTANT NOTICE

Wolfson Microelectronics plc (“Wolfson”) products and services are sold subject to Wolfson’s terms and conditions of sale, delivery and payment supplied at the time of order acknowledgement.

Wolfson warrants performance of its products to the specifications in effect at the date of shipment. Wolfson reserves the right to make changes to its products and specifications or to discontinue any product or service without notice. Customers should therefore obtain the latest version of relevant information from Wolfson to verify that the information is current.

Testing and other quality control techniques are utilised to the extent Wolfson deems necessary to support its warranty. Specific testing of all parameters of each device is not necessarily performed unless required by law or regulation.

In order to minimise risks associated with customer applications, the customer must use adequate design and operating safeguards to minimise inherent or procedural hazards. Wolfson is not liable for applications assistance or customer product design. The customer is solely responsible for its selection and use of Wolfson products. Wolfson is not liable for such selection or use nor for use of any circuitry other than circuitry entirely embodied in a Wolfson product.

Wolfson’s products are not intended for use in life support systems, appliances, nuclear systems or systems where malfunction can reasonably be expected to result in personal injury, death or severe property or environmental damage. Any use of products by the customer for such purposes is at the customer’s own risk.

Wolfson does not grant any licence (express or implied) under any patent right, copyright, mask work right or other intellectual property right of Wolfson covering or relating to any combination, machine, or process in which its products or services might be or are used. Any provision or publication of any third party’s products or services does not constitute Wolfson’s approval, licence, warranty or endorsement thereof. Any third party trade marks contained in this document belong to the respective third party owner.

Reproduction of information from Wolfson datasheets is permissible only if reproduction is without alteration and is accompanied by all associated copyright, proprietary and other notices (including this notice) and conditions. Wolfson is not liable for any unauthorised alteration of such information or for any reliance placed thereon.

Any representations made, warranties given, and/or liabilities accepted by any person which differ from those contained in this datasheet or in Wolfson’s standard terms and conditions of sale, delivery and payment are made, given and/or accepted at that person’s own risk. Wolfson is not liable for any such representations, warranties or liabilities or for any reliance placed thereon by any person.

ADDRESS:

Wolfson Microelectronics plc
Westfield House
26 Westfield Road
Edinburgh
EH11 2QB
United Kingdom
Tel :: +44 (0)131 272 7000
Fax :: +44 (0)131 272 7001
Email :: apps@wolfsonmicro.com