

All of us have experienced trying to make a mobile phone call from a noisy street, crowded restaurant or train station where the background noise can make it impossible to hear the incoming call. It can be worse when the person next to you in these situations is yelling into the receiver in an attempt to be heard. Active and passive noise cancelling technologies can minimize background noise in high end headphones; however these technologies today can not provide the same benefits in mobile handsets. Clearly mobile handsets could benefit from noise cancellation. Active noise cancellation (ANC) has been used in headphones for several years, often used to cut out the drone of an aircraft on a long journey. But the full benefit of the technology has not been realized – the potential is for noise cancellation to be used in a much wider range of applications creating a field of quiet for users of a range of consumer equipment. A highly effective noise cancelling scheme would not only benefit consumers by helping to save our hearing, but carriers would benefit from longer calls, more calls and more satisfied consumers resulting in higher revenues.

In current mobile phone handsets the voice signal that is taken in from the microphone in the phone can be filtered and improved, creating a high quality link from you to the other person on the call, but receiving a call in a busy place can make the voice of the person calling you inaudible. Being able to create a field of quiet around the handset earpiece without relying on impractical passive noise cancellation, is a particularly exciting possibility for mobile phones.

The technology of ANC has moved down from the high end into mid range headphones, but it has remained pretty much in headphones. Part of the problem has been the feedback ANC technology that most of these headphones use. This technology tries to create a stable null; a microphone measures the noise inside the headphone 'cans' and a circuit generates a cancellation signal which is sent to the headphone speaker. However this technique is limited in the frequencies that can be cancelled, and most often it needs significant sound proofing around the earphones to block out the external noise through passive noise cancellation.

Mobile phones

In current mobile phone handsets the voice signal that is taken in from the microphone can be filtered and improved, creating a high quality transmit link from you to the other person on the call. But receiving a call in a busy place can make the voice of the person calling you unintelligible.

ANC is an attractive feature for makers of high end phones for developed markets. Imagine a business phone that lets you clearly hear the information that a colleague is communicating to you when you are on a noisy train, or a phone that allowed you to receive a friend's call in a busy restaurant without needing to go outside to hear them.

But this approach is also of interest to the low end phone makers and network operators in developing markets where callers are often struggling to complete calls in very noisy street environments. Also, using technology in the handset to improve the quality of the call means that the network can stretch further for the same level of signal quality, either bringing phones to more customers with the same infrastructure equipment or reducing the roll out of new infrastructure equipment.

Implementing this technology in mobile phones is a very significant challenge, not only in making the technology work, but to make it work cost effectively for designs that are manufactured in the tens of millions of units. That is not a trivial challenge.

Types of noise cancellation

Passive noise cancellation involves insulation and absorption, typically in the form of cups or cans that surround the ear. This works fine for headphones that are used to listen to music or drown out unwanted sounds on airplanes. Clearly, passive noise cancellation isn't practical for a mobile handset. Active noise cancellation can be classified as feedback or feed-forward. In headphones a feedback approach is typically used with passive noise cancellation. The headphone "cans" create a sealed cavity over the listener's ear. The noise inside the can is then monitored using a microphone and an electronic feedback circuit is used to generate a noise cancellation signal which tries to create a null, silence, inside the can. It is clearly not practical to create such a sealed cavity around the ear of a person using a mobile phone.

Challenges of receive side noise cancellation

The Wolfson ANC technology uses feed-forward architecture rather than the traditional feedback approach. This also uses microphones to capture the ambient noise, but instead of using feedback to create a null it inverts the noise signal and generates a field of sound timed to cancel the noise as it hits the eardrum. This avoids the need for cans around the headphones, or the need for passive cancellation at all. However, there are major challenges to this approach, both technical and commercial. There is limited time to do the signal processing, inverting the signal, calculating the time shift that is needed, and producing the output waveforms for the speaker. All this needs to be done in the time it takes for the ambient noise signal passing the noise monitoring microphones till the same signal reaches the ear. The generated cancellation signal also has to be exactly phase aligned to ensure that the noise is correctly cancelled. If done correctly this creates the field of quiet around the ear so that the audio signal is clearer regardless of the noisy environment.

The other challenge is commercial. Phones use a wide range of microphones and speakers, and such a system has to be easily designed into a specific phone. Having a configurable approach where different parameters can be easily programmed into different phones to optimize the signal processing is vital to get the level of performance required to make a difference to the user experience. For low end phones, this also has to be a cost effective solution that does not add expensive components to the bill of materials of the phone.

While there is significant processing power available in a phone through the baseband processor, there is not enough time to route the signal through the phone to the processor and still achieve good levels of ANC. This processing power has to be added to the audio signal chain in a cost effective way, but also not compromise the existing sound quality or the battery life. Traditional feedback-based ANC headphones use an additional battery to power the signal processing. Mobile handset designers don't have the luxury of adding an additional battery. The ANC approach in a mobile phone has to have a negligible impact on the talk time and standby time of the phone.

Proposed implementation

Wolfson Microelectronics has a number of patent/patent applications for a new feed-forward approach that addresses the needs of the mobile phone and portable consumer equipment maker. These patent/patent applications cover the time alignment and signal processing techniques that remove the latency from the signal chain to provide an implementation in which the ambient noise and noise cancellation signals are time and phase aligned.

This implementation uses two microphones on the edge of the phone to the left and right of the earphone speaker. They intercept the ambient noise, feed it to a signal processor that generates the anti-noise signal, and feeds it to the earphone speaker. The signal processor also has to take into account how quickly the speaker responds to particular frequencies to ensure all the frequencies are time- and phase-aligned.

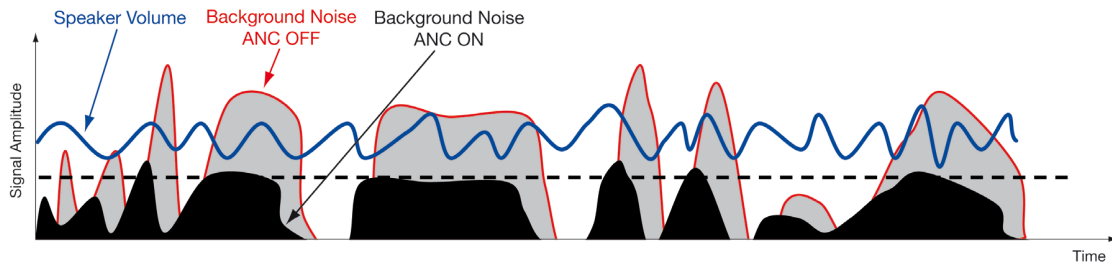

Figure 1 Simplified effects of Wolfson ANC

Figure 1 shows an example of the effects of the Wolfson ANC. The blue line represents a voice signal. The red shape represents a background noise signal, often higher in amplitude than the voice signal, making the voice inaudible. The black shape indicates what the noise signal would look like with the Wolfson ANC turned on.

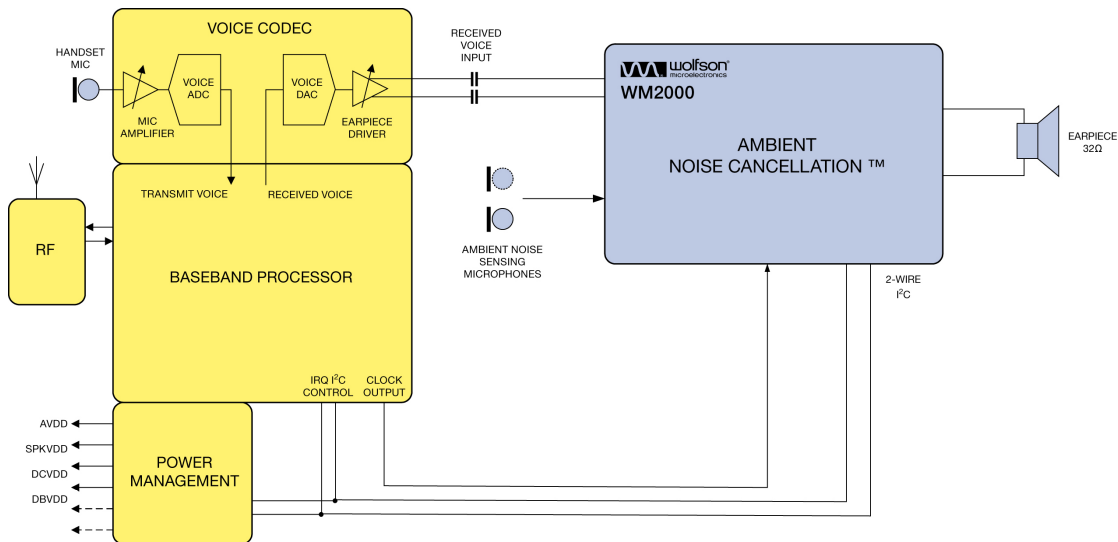

Figure 2 Block diagram of receive active noise cancellation

The implementation shown in Figure 2 uses two standard microphones, and a signal processing chip from Wolfson that replaces the speaker driver.

The signal processing chip holds a set of parameters for different elements of the signal chain and these can be tuned to the acoustic characteristics of a particular handset design. These include the latencies of different speakers, different form factors such as clam-shell or candy bar phones and the microphone signal-to-noise ratio.

Wolfson ANC technology is already being used for ear-bud headphones and is now being designed into mobile phones.

In future it will also be used in portable equipment such as personal media players to improve the quality of sound for games and video, and user tests have shown that improving the audio performance of a system dramatically improves the overall user experience.

Future trends

In order to continue to reduce the cost and size of mobile handsets, additional opportunities for integration must be explored. The integration of transmit path noise cancellation is one possibility, as this would offer handset vendors a convenient single chip solution for noise entering the handset and transmitted through the network as well as for the same noise making it hard for the handset user to hear the voice call. There is also potential to integrate the signal processing with silicon microphones. Integration steps such as these would reduce the noise in the system, improve the performance, and require less power, while reducing the overall bill of materials and complexity of the phone design.

Conclusion

Active noise cancellation is a powerful tool for improving the user experience in mobile phones and also improving the economics and user satisfaction of mobile phone networks. It has not been possible to apply feedback ANC techniques to mobile phones due to the need for passive noise cancellation and the need to create a sealed cavity around the ear of the listener. With a feed forward architecture combined with the patented and novel time alignment and signal processing techniques developed by Wolfson, it is now possible to provide very effective noise cancellation in a phone at a cost that is acceptable for both high end and low end phone makers.